

(19) World Intellectual Property
Organization
International Bureau



(43) International Publication Date
27 January 2005 (27.01.2005)

PCT

(10) International Publication Number
WO 2005/006990 A2

- (51) International Patent Classification⁷: **A61B 17/00**
- (21) International Application Number:
PCT/US2004/022643
- (22) International Filing Date: 14 July 2004 (14.07.2004)
- (25) Filing Language: English
- (26) Publication Language: English
- (30) Priority Data:
60/486,992 14 July 2003 (14.07.2003) US
- (71) Applicant (for all designated States except US): **NMT MEDICAL, INC.** [US/US]; 27 Wormwood Street, Boston, MA 02210 (US).
- (72) Inventor; and
- (75) Inventor/Applicant (for US only): **CHANDUSZKO, Andrzej, J.** [US/US]; 311 N. Carriage Lane, Chandler, AZ 85224 (US).
- (74) Agents: **CAVANAUGH, David, L.** et al.; Wilmer Cutler Pickering Hale and Dorr LLP, 60 State Street, Boston, MA 02109 (US).
- (81) Designated States (unless otherwise indicated, for every kind of national protection available): AE, AG, AL, AM, AT, AU, AZ, BA, BB, BG, BR, BW, BY, BZ, CA, CH, CN, CO, CR, CU, CZ, DE, DK, DM, DZ, EC, EE, EG, ES, FI, GB, GD, GE, GH, GM, HR, HU, ID, IL, IN, IS, JP, KE, KG, KP, KR, KZ, LC, LK, LR, LS, LT, LU, LV, MA, MD, MG, MK, MN, MW, MX, MZ, NA, NI, NO, NZ, OM, PG, PH, PL, PT, RO, RU, SC, SD, SE, SG, SK, SL, SY, TJ, TM, TN, TR, TT, TZ, UA, UG, US, UZ, VC, VN, YU, ZA, ZM, ZW.
- (84) Designated States (unless otherwise indicated, for every kind of regional protection available): ARIPO (BW, GH, GM, KE, LS, MW, MZ, NA, SD, SL, SZ, TZ, UG, ZM, ZW), Eurasian (AM, AZ, BY, KG, KZ, MD, RU, TJ, TM), European (AT, BE, BG, CH, CY, CZ, DE, DK, EE, ES, FI, FR, GB, GR, HU, IE, IT, LU, MC, NL, PL, PT, RO, SE, SI, SK, TR), OAPI (BF, BJ, CF, CG, CI, CM, GA, GN, GQ, GW, ML, MR, NE, SN, TD, TG).
- Published:**
— without international search report and to be republished upon receipt of that report
- For two-letter codes and other abbreviations, refer to the "Guidance Notes on Codes and Abbreviations" appearing at the beginning of each regular issue of the PCT Gazette.

(54) Title: TUBULAR PATENT FORAMEN OVALE (PFO) CLOSURE DEVICE WITH CATCH SYSTEM

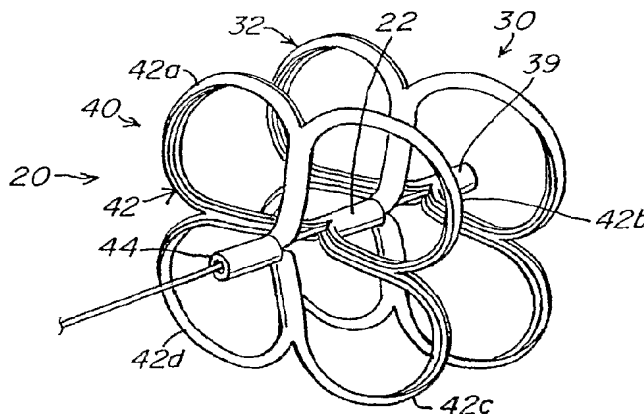

(57) Abstract: The present invention provides a device for occluding an anatomical aperture, such as an atrial septal defect (ASD) or a patent foramen ovale (PFO). The occluder includes two sides connected by a central tube. The occluder is formed from a tube, which is cut to produce struts in each side. Upon the application of force, the struts deform into loops. The loops may be of various shapes, sizes, and configurations, and, in at least some embodiments, the loops have rounded peripheries. In some embodiments, at least one of the sides includes a tissue scaffold. The occluder further includes a catch system that maintains its deployed state *in vivo*. When the occluder is deployed *in vivo*, the two sides are disposed on opposite sides of the septal tissue surrounding the aperture and the catch system is deployed so that the occluder exerts a compressive force on the septal tissue and closes the aperture.



WO 2005/006990 A2

TUBULAR PATENT FORAMEN OVALE (PFO) CLOSURE DEVICE WITH CATCH SYSTEM

Field of the Invention

[0001] The present invention relates generally to an occlusion device for the
5 closure of physical anomalies, such as an atrial septal defect, a patent foramen ovale,
and other septal and vascular defects.

Background of the Invention

[0002] A patent foramen ovale (PFO), illustrated in Figure 1, is a persistent, one-
way, usually flap-like opening in the wall between the right atrium **11** and left atrium
10 **13** of the heart **10**. Because left atrial (LA) pressure is normally higher than right
atrial (RA) pressure, the flap usually stays closed. Under certain conditions, however,
right atrial pressure can exceed left atrial pressure, creating the possibility that blood
could pass from the right atrium **11** to the left atrium **13** and blood clots could enter
the systemic circulation. It is desirable that this circumstance be eliminated.

15 [0003] The foramen ovale serves a desired purpose when a fetus is gestating in
utero. Because blood is oxygenated through the umbilical chord, and not through the
developing lungs, the circulatory system of the fetal heart allows the blood to flow
through the foramen ovale as a physiologic conduit for right-to-left shunting. After
birth, with the establishment of pulmonary circulation, the increased left atrial blood
20 flow and pressure results in functional closure of the foramen ovale. This functional
closure is subsequently followed by anatomical closure of the two over-lapping layers
of tissue: septum primum **14** and septum secundum **16**. However, a PFO has been
shown to persist in a number of adults.

[0004] The presence of a PFO is generally considered to have no therapeutic
25 consequence in otherwise healthy adults. Paradoxical embolism via a PFO is
considered in the diagnosis for patients who have suffered a stroke or transient
ischemic attack (TIA) in the presence of a PFO and without another identified cause
of ischemic stroke. While there is currently no definitive proof of a cause-effect
relationship, many studies have confirmed a strong association between the presence
30 of a PFO and the risk for paradoxical embolism or stroke. In addition, there is

significant evidence that patients with a PFO who have had a cerebral vascular event are at increased risk for future, recurrent cerebrovascular events.

5 [0005] Accordingly, patients at such an increased risk are considered for prophylactic medical therapy to reduce the risk of a recurrent embolic event. These patients are commonly treated with oral anticoagulants, which potentially have adverse side effects, such as hemorrhaging, hematoma, and interactions with a variety of other drugs. The use of these drugs can alter a person's recovery and necessitate adjustments in a person's daily living pattern.

10 [0006] In certain cases, such as when anticoagulation is contraindicated, surgery may be necessary or desirable to close a PFO. The surgery would typically include suturing a PFO closed by attaching septum secundum to septum primum. This sutured attachment can be accomplished using either an interrupted or a continuous stitch and is a common way a surgeon shuts a PFO under direct visualization.

15 [0007] Umbrella devices and a variety of other similar mechanical closure devices, developed initially for percutaneous closure of atrial septal defects (ASDs), have been used in some instances to close PFOs. These devices potentially allow patients to avoid the side effects often associated with anticoagulation therapies and the risks of invasive surgery. However, umbrella devices and the like that are designed for ASDs are not optimally suited for use as PFO closure devices.

20 [0008] Currently available septal closure devices present drawbacks, including technically complex implantation procedures. Additionally, there are not insignificant complications due to thrombus, fractures of the components, conduction system disturbances, perforations of heart tissue, and residual leaks. Many devices have high septal profile and include large masses of foreign material, which may lead to unfavorable body adaptation of a device. Given that ASD devices are designed to occlude holes, many lack anatomic conformability to the flap-like anatomy of PFOs. Thus, when inserting an ASD device to close a PFO, the narrow opening and the thin flap may form impediments to proper deployment. Even if an occlusive seal is formed, the device may be deployed in the heart on an angle, leaving some components insecurely seated against the septum and, thereby, risking thrombus formation due to hemodynamic disturbances. Finally, some septal closure devices are complex to manufacture, which may result in inconsistent product performance.

25
30

[0009] The present invention is designed to address these and other deficiencies of prior art septal closure devices.

Summary of the Invention

5 [0010] In one aspect, the present invention provides a device for occluding an aperture in septal tissue, including a first side adapted to be disposed on one side of the septal tissue and a second side adapted to be disposed on the opposite side of the septal tissue. The first and second sides are adapted to occlude the aperture upon deployment of the device at its intended delivery location. The device also includes a catch system that maintains the configuration of the device once it has been deployed.

10 [0011] According to some embodiments, the catch system reduces and maintains the axial length of the device. Also, varied constructions could be used to maintain the axial dimension of the device. In one form, catch elements such as, e.g., balls, attached to a delivery wire could be used to maintain the axial dimension of the device. In a different construction, a locking mechanism could be used. Preferably, if
15 a locking mechanism is used, it secures both sides of the device in the locked position with a single locking element.

[0012] According to at least some embodiments, the device is formed from a tube. According to some embodiments, the tube includes a material selected from the group consisting of metals, shape memory materials, alloys, polymers, bioabsorbable
20 polymers, and combinations thereof. In particular embodiments, the tube includes a shape memory polymer. According to some embodiments, the device is formed by cutting the tube.

[0013] According to some embodiments, at least one of the first and second sides of the device includes a tissue scaffold. According to some embodiments, the tissue
25 scaffold includes a material selected from the group consisting of polyester fabrics, Teflon-based materials, polyurethanes, metals, polyvinyl alcohol (PVA), extracellular matrix (ECM) or other bioengineered materials, synthetic bioabsorbable polymeric scaffolds, collagen, and combinations thereof. In particular embodiments, the tissue scaffold includes nitinol.

30 [0014] According to some embodiments, the first and second sides of the device are connected by a central tube. According to some embodiments, the central tube is

positioned so as to minimize distortion to the septal tissue surrounding the aperture. In particular embodiments, the central tube is positioned at an angle θ from the second side, and the angle θ is greater than 0 degrees and less than about 90 degrees.

[0015] In another aspect, the present invention provides a device for occluding an
5 aperture in septal tissue, including a first side adapted to be disposed on one side of the septal tissue and a second side adapted to be disposed on the opposite side of the septal tissue. The first and second sides are adapted to occlude the defect when the device is deployed at its intended delivery location. Each of the first and second sides includes loops. The device further includes a catch system that maintains the
10 configuration of the device once it has been deployed. The loops of the first and second sides and the catch system cooperate to provide a compressive force to the septal tissue surrounding the aperture.

[0016] According to some embodiments, each of the first and second sides includes at least two loops. In particular embodiments, each of the first and second
15 sides includes four or six loops. Of course, the most desirable number of loops on each side will depend on a variety of anatomical and manufacturing factors.

[0017] According to some embodiments, the device also includes a central tube that connects the first and second sides. According to some embodiments, the central tube is positioned so as to minimize distortion to the septal tissue surrounding the
20 aperture. In particular embodiments, the central tube is positioned at an angle θ from the second side, and the angle θ is greater than 0 degrees and less than about 90 degrees.

[0018] According to some embodiments, the device is formed from a tube. According to some embodiments, the tube includes a material selected from the group
25 consisting of metals, shape memory materials, alloys, polymers, bioabsorbable polymers, and combinations thereof. In particular embodiments, the tube includes nitinol. In particular embodiments, the tube includes a shape memory polymer.

[0019] According to some embodiments, at least one of the first and second sides further includes a tissue scaffold. According to some embodiments, the tissue
30 scaffold includes a material selected from the group consisting of polyester fabrics, Teflon-based materials, polyurethanes, metals, polyvinyl alcohol (PVA), extracellular matrix (ECM) or other bioengineered materials, synthetic bioabsorbable polymeric

scaffolds, collagen, and combinations thereof. In particular embodiments, the tissue scaffold includes nitinol.

[0020] According to some embodiments, each of the loops includes a rounded edge at its periphery to minimize trauma to the septal tissue. In particular
5 embodiments, the outer periphery of the device is circular.

[0021] In still another aspect, the present invention provides a method of making a device for occluding an aperture in septal tissue, including providing a tube having first and second ends and upper and lower portions, cutting at least four axially-
10 extending openings in the upper portion of the tube, cutting at least four axially-
extending openings in the lower portion of the tube. The openings in the upper and lower portions are separated by a central portion of the tube.

[0022] According to some embodiments, the tube includes a material selected from the group consisting of metals, shape memory materials, alloys, polymers, bioabsorbable polymers, and combinations thereof. In particular embodiments, the
15 tube includes a shape memory polymer.

[0023] In yet another aspect, the present invention provides a method of occluding an aperture in septal tissue, including providing a tube having first and second ends and upper and lower portions in a delivery sheath. The tube includes at least four axially-extending openings in its upper portion and at least three axially-extending
20 openings in its lower portion. The openings in the upper and lower portions are separated by a central portion of the tube. The delivery sheath is inserted into a right atrium of a heart, through the aperture in the septal tissue, and into the left atrium of the heart. The first end and the upper portion of the tube are deployed into the left atrium. The sheath is then retracted through the aperture and into the right atrium of
25 the heart, where the second end and the lower portion of the tube are deployed into the right atrium. The sheath is then withdrawn from the heart. Of course, a catch system could be used to secure the device in a delivered (expanded) state. The catch system may have any or all the characteristics described in the specification. Further, other types of catch systems could be used to hold the device in the delivered state.

[0024] According to some embodiments, a force is applied to each of the first and second ends in an axial direction such that the axial length of the tube is reduced. The
30

force applied to the first end is in a direction opposite to that of the force applied to the second end.

Brief Description of the Drawings

5 [0025] Figure 1 is a schematic representation of a human heart including various septal defects;

[0026] Figures 2A-2D are isometric views of an embodiment of an occluder according to the present invention;

[0027] Figures 3A-3C are front elevational, side, and cross-sectional views, respectively, of the occluder of Figures 2A-2D;

10 [0028] Figures 4A-4B are front elevational and side views, respectively, of another embodiment of an occluder according to the present invention;

[0029] Figures 5A-5B are front and side views, respectively, of still another embodiment of an occluder according to the present invention;

15 [0030] Figures 6A-6E are isometric views of one embodiment of a catch system according to the present invention;

[0031] Figures 7A-7C are side views of another embodiment of a locking mechanism according to the present invention;

[0032] Figures 8A-8C are isometric views of yet another embodiment of an occluder according to the present invention;

20 [0033] Figures 9A-9H are side views of one method for delivering an occluder according to the present invention to a septal defect; and

[0034] Figures 10A-10D are side views of one method for retrieving an occluder according to the present invention from a septal defect

25 [0035] Figures 11A-11C are isometric views of occluders according to various embodiments of the invention;

[0036] Figures 12A and 12B are side and top views, respectively, of an alternate embodiment of an occluder according to the present invention;

[0037] Figure 13 is a side view of an embodiment of the occluder of the present invention; and

30 [0038] Figure 14 is an isometric view of an embodiment of the occluder of the present invention;

[0039] Figure 15 is a side view of the occluder of Figures 11A-11C deployed *in vivo*.

Detailed Description of the Invention

[0040] The present invention provides a device for occluding an aperture within
5 body tissue. In particular and as described in detail below, the occluder of the present invention may be used for closing an ASD or PFO in the atrial septum of a heart. Although the embodiments of the invention are described with reference to an ASD or PFO, one skilled in the art will recognize that the device and methods of the present invention may be used to treat other anatomical conditions. As such, the invention
10 should not be considered limited in applicability to any particular anatomical condition.

[0041] Figure 1 illustrates a human heart **10**, having a right atrium **11** and a left atrium **13** and including various anatomical anomalies **18a** and **18b**. The atrial septum **12** includes septum primum **14** and septum secundum **16**. The anatomy of the
15 septum **12** varies widely within the population. In some people, septum primum **14** extends to and overlaps with septum secundum **16**. The septum primum **14** may be quite thin. When a PFO is present, blood could travel through the passage **18a** between septum primum **14** and septum secundum **16** (referred to as “the PFO tunnel”). Additionally or alternatively, the presence of an ASD could permit blood to
20 travel through an aperture in the septal tissue, such as that schematically illustrated by aperture **18b**.

[0042] In this application, “distal” refers to the direction away from a catheter insertion location and “proximal” refers to the direction nearer the insertion location.

[0043] The occluder **20** may be further varied by altering the cutting pattern on
25 tube **25**. For example, and as shown in Figures 2A, 2B-2D, and 3A-3C, petal-shaped loops **32** (Figures 2A-2D and Figure 3A) are produced by cutting slits **31** in the upper portion of tube **25** according to the cutting pattern shown in Figure 2A. As shown in Figure 2B, tube **25** is cut in half to form half sections **91a** and **91b**. The half sections **91a** and **91b** are further cut to a proximal distance from end **39** into quarter sections
30 **92a**, **93a**, **92b**, and **93b**. The cuts are discontinued and quarter sections **92a** and **93a** form half section **94a** at end **39**, and quarter sections **92b** and **93** form half section

94b at end 39. Upon application of force F_d to end 39, struts 32 bow and twist outward to form petal-shaped loops 32 in distal side 30, as shown in Figures 2C-2D.

The movement of the struts during deployment is such that the struts rotate in an orthogonal plane relative to the axis of the device. Central tube 22 may be

5 constrained during the application of force F_d , or any combination of forces sufficient to reduce the axial length of the tube 25 may be applied. One end of each of petal-shaped loops 32 originates from central tube 22, while the other end originates from end 39 (Figures 2B-2C and Figure 3A). Petal-shaped loops 42 may be formed in proximal side 40, as shown in Figures 2B-2D, using the same cutting pattern
10 described above.

[0044] Given that the surface of occluder 20 will contact septal tissue 12 once it is deployed *in vivo*, slits 31 and 41 are further cut so as to prevent the formation of sharp, potentially damaging edges along their length. For example, a heated cutting tool may be used to cut slits 31 and 41 such that the material of tube 25 melts slightly
15 when placed in contact with the cutting tool. Such melting rounds the edges of the sections. Lasers may also be used to cut slits 31 and 41. According to this process, the edges of loops 32 formed by the cutting of slits 31 and 41 are blunted (due to melting) to prevent tissue damage *in vivo*.

[0045] The tube(s) 25 forming occluder 20 includes a biocompatible metal or
20 polymer. In at least some embodiments, the occluder 20 is formed of a bioresorbable polymer, or a shape memory polymer. Shape memory polymers can be advantageous so that the structure of the device assists in pressing the PFO tunnel closed. In other embodiments, the occluder 20 is formed of a biocompatible metal, such as a shape memory alloy (*e.g.*, nitinol). The thermal shape memory and/or superelastic
25 properties of shape memory polymers and alloys permit the occluder 20 to resume and maintain its intended shape *in vivo* despite being distorted during the delivery process. Alternatively, or additionally, the occluder 20 may be formed of a bioresorbable metal, such as iron, magnesium, or combinations of these and similar materials. The cross-sectional shape of tube 25 may be circular or polygonal, for
30 example square, or hexagonal. The slits 31 and 41 may be disposed on the face of the polygon (*i.e.*, the flat part) or on the intersection of the faces.

[0046] The tube can be extruded or constructed of a sheet of material and rolled into a tube. The sheet of material could be a single ply sheet or multiple ply. The slits that form the struts could be cut or stamped into the tube prior to rolling the tube to connect the ends to form an enclosed cross section. Various geometrical cross sections are possible including circular, square, hexagonal and octagonal and the joint could be at the vertex or along the flat of a wall if the cross section is of a particular geometry. Various attachment techniques could be used to join the ends of the sheet to form a tube, including welding, heat adhesives, non-heat adhesives and other joining techniques suitable for in-vivo application.

10 [0047] The surface of tube 25 may be textured or smooth. An occluder 20 having a rough surface produces an inflammatory response upon contact with septal tissue 12 *in vivo*, thereby promoting faster tissue ingrowth, healing, and closure of aperture 18a (shown in Fig. 1). Such a rough surface may be produced, for example, by shaving tube 25 to produce whiskers along its surface. For example, central tube 22 may include such whiskers. Additionally or alternatively, the surface of tube 25 may be porous to facilitate cell ingrowth.

[0048] The distal side 30 of the occluder 20 (also called the “anchor portion”) is shown in Figure 2C and 2D. The distal side 30 includes four loops 32a, 32b, 32c, and 32d (collectively referred to as loops 32). As previously described, each of loops 32a-32d are formed by corresponding struts 32a-32d produced by cutting slits 31. The application of force F_d to end 39 of tube 25 brings the axial ends of slits 31 together such that struts 32 bow and twist outwardly to form loops 32 of distal side 30 (Figures 2B-2C). Central tube 22 may be constrained during the application of force F_d . One skilled in the art will recognize that any combination of forces sufficient to reduce the axial length of the tube 25 would be sufficient to deploy the distal side 30 of occluder 20.

25 [0049] As illustrated, the loops 32 are evenly distributed about central tube 22 and end 39. Thus, when proximal side 30 includes four loops 32 (as shown in Figures 2C and 2D), the four slits 31 are spaced 90 degrees apart. Similarly, when proximal side 30 includes six loops 32, the six slits 31 are spaced 60 degrees apart. The angle between equally-spaced slits 31 in proximal side 30 is determined by the formula $(360/n_d)$.

[0050] Although the distal side **30** of the occluder **20** shown in Figure 3A includes four loops **32**, occluders according to the present invention may include any number of loops **32** necessary for a given application. In particular embodiments, the distal side **30** of occluder **20** includes six loops (Figure 4A). Occluders having between four
5 and ten loops **32** may be formed without requiring significant adjustments in the processes described in this application. However, occluders having less than four or more than ten loops **32** may be complicated to manufacture and deliver through the vasculature.

[0051] Regardless of the number of loops included in distal side **30** and depending
10 upon the material used to form occluder **20**, the outer shape of loops **32** may vary. In at least some embodiments, the loops **32** are rounded to provide an occluder **20** having a smooth, circular perimeter. As the number of loops **32** in the distal side **30** of occluder **20** increases, it becomes desirable to round the outer perimeters of the loops **32** so as to prevent the infliction of trauma on the surrounding septal tissue **12**.

[0052] The proximal side **40** of the occluder **20**, shown in side view in Figure 2D,
15 also includes four loops, **42a**, **42b**, **42c**, and **42d** (collectively referred to as loops **42**). As previously described, each of loops **42a-42d** are formed by cutting slits **41**. The application of force F_p to end **44** of tube **25** brings the axial ends of slits **41** together such that struts **42** bow and twist outwardly to form loops **42** of proximal side **40**
20 (Figures 2C-2D). Central tube **22** may be constrained during the application of force F_p . One skilled in the art will recognize that any combination of forces sufficient to reduce the axial length of the tube **25** would be sufficient to deploy the proximal side **40** of occluder **20**. As described above for distal side **30**, the loops **42** are evenly distributed about central tube **22** and tip **44**.

[0053] Although the proximal side **40** of the occluder **20** shown in Figure 2D
25 includes four loops **42**, one skilled in the art will recognize that the proximal side **40** of an occluder according to the present invention may include any number of loops **42** required and suitable for a given application. In particular embodiments, the proximal side **40** of occluder **20** includes six loops **42** (Figure 4A). Further, although
30 illustrated, distal side **30** and proximal side **40** both include four loops, there is no requirement that distal side **30** and proximal side **40** include the same number of

loops. In fact, in particular applications, it may be advantageous to use an occluder **20** in which distal side **30** contains fewer loops than proximal side **40**, or vice versa.

[0054] In at least some embodiments, illustrated in Figures 4A and Figures 12A-12B, the loops **42** of the proximal side **40** are rotated with respect to the loops **32** of the distal side **30** to provide a better distribution of forces around the aperture **18a**.
5 For example, proximal slits **41** may be rotated such that they are offset from distal slits **31** by half the angle between adjacent slits on the distal side **30**, *e.g.*, when distal side **30** and proximal side **40** of occluder **20** each have four loops **32** and **42**, respectively, proximal slits **41** are rotated 30-45 degrees with respect to slits **31**.
10 Thus, in a preferred form, as shown in Figure 12A, proximal slits **41** are rotated 45 degrees (as indicated by angle ϕ) with respect to distal slits **31**. Correspondingly, as shown in Figure 12B, proximal loops **42** are rotated 45 degrees with respect to distal loops **32** (as indicated by angle ϕ).

[0055] Further, loops **32** of distal side **30** may be bent to form concave loops, while loops **42** of proximal side **40** may be flat (Figure 13). In this embodiment, the outermost portions of loops **42** of proximal side **40** oppose the outermost portions of the loops **32** of the proximal side **30**, as described in more detail below, thereby creating a desirable opposing force that secures the occluder **20** at its desired location *in vivo*. So configured, the opposing compressive forces exerted by sides **30** and **40**
15 on the septal tissue **12** following deployment of occluder **20** *in vivo* is advantageous in certain circumstances, such as closing certain kinds of PFOs.
20

[0056] Whatever the number and shapes of loops **32** and **42**, the loops **32** and **42** may be of varied sizes to facilitate delivery of occluder **20**, *e.g.* to improve collapsibility of the occluder **20** or to enhance its securement at the delivery site. For example, loops **32** and **42** sized to better conform with anatomical landmarks enhance securement of the occluder **20** to the septal tissue **12** *in vivo*. As indicated above, the cross-sectional dimensions of loops **32** and **42** are determined by the thickness of tube **25** and the distance between adjacent slits **31** and **41**. The length of slits **31** and **41** determines the length of loops **32** and **42** and the radial extent of the deployed
25 occluder **20**. In at least some embodiments, each of distal side **30** and proximal side **40** has a diameter in the range of about 10 mm to about 45 mm, with the particular diameter determined by the size of the particular defect being treated. In particular
30

embodiments, the diameter of distal side **30** will be different than that of proximal side **40** so as to better conform to the anatomy of the patient's heart.

[0057] The struts which form the loops may be constructed as illustrated in Figure 2B. That is, about 1/3 the length of the slit is 91a, 1/3 of the length of the slit
5 is the distance of 93b and the final third of the slit is the length of 94b. Of course other dimensions would produce advantageous results. In general, the longer the length of the hemispherical (as shown) struts, the stiffer the occluder will be. The longer the length of the quarter (as shown) struts, the less stiff the occluder will be. In other words, the hemispherical cut (one of the two) may be 20 – 40 percent of the
10 overall length of the cuts along the tube. Specifically, the hemispherical cuts could be 40 % of the overall length and then the quarter cut be 20 % of the cut. Also, the lengths of the hemispherical cuts need not be the same. It may be advantageous to shorten one or the other side of the hemispherical cut based on a desired stiffness characteristic for a particular application of the occluder. In an alternative structure,
15 the cuts can be extended in a range up to 100 percent of the length of one side of the occluding member while still enabling the bow and twist of the struts.

[0058] As indicated previously and shown in Figures 2A and Figure 2D, distal side **30** and proximal side **40** of occluder **20** are connected by central tube **22**. The central tube **22** is formed by that portion of tube **25** between the upper portion of tube
20 **25**, which contains slits **31**, and the lower portion of tube **25**, which contains slits **41**. Given that the central portion of tube **25** remains uncut during the cutting process, the central portion of the tube maintains its profile upon the application of forces F_d and F_p and does not bow and twist outward as the proximal and distal sides are adapted to do.

[0059] Central tube **22** may be straight or positioned at an angle θ , as shown in Figure 13. The type of central tube **22** included in a given occluder is, at least in part, determined by the nature of the aperture **18**. An occluder having a straight central tube **22** is particularly suited to treat an anatomical anomaly including a perpendicular aperture, such as an ASD and certain PFOs. Often, however, anatomical anomalies,
30 such as certain PFOs, have non-perpendicular apertures and are sometimes quite significantly non-perpendicular. An occluder having an angled central tube **22** is well-suited for treatment of such defects, such that the angle of the anatomical

aperture **18** is more closely matched by the pre-formed angle θ of the occluder **20**. Also, the length of the center tube should be varied depending on the anatomy of the defect being closed. Accordingly, the distal side **30** and proximal side **40** of occluder **20** are more likely to be seated against and minimize distortion to the septal tissue **12** surrounding the aperture **18**, as shown in Figure 15. A well-seated occluder **20** is less likely to permit blood leakage between the right **11** and left **13** atria, and the patient into which the occluder **20** has been placed is, therefore, less likely to suffer embolisms and other adverse events. Advantageously, angled central tube **22** also facilitates delivery of occluder **20** because it is angled toward the end of the delivery sheath. In at least some embodiments, the angle θ is about 0-45 degrees off the plane created by the proximal side **40**. Proximal side **40** may bend depending upon, among other factors, the material used to form occluder **20**. Accordingly, depending upon design considerations, tip **44** and end **39** may be aligned with central tube **22** or perpendicular to proximal side **40** or some variation in between. One skilled in the art will be capable of determining whether a straight or angled central tube **22** is best suited for treatment of a given anatomical aperture **18** and the appropriate angle θ , typically in the range between 0 and 45 degrees or even to 90 degrees if used in an oblique passageway such as a very long tunnel PFO, for a given angled central tube **22**. Further, one skilled in the art will recognize that the concept of an angled central tube may be applied to septal occluders other than those disclosed herein.

[0060] When central tube **22** is positioned at angle θ , distal side **30** and proximal side **40** of occluder **20** may be configured such that they are either directly opposing or, as shown in Figures 5B, 13 and 14, offset by distance **A**. One skilled in the art will, of course, recognize that the shape and arrangement of either or both of distal side **30** and proximal side **40** may be adjusted such that the compressive forces they apply are as directly opposing as possible. However, in some clinical applications, an occluder **20** having an offset of distance **A** may be particularly desirable. For example, as shown in Figures 13-14, if the septal tissue **12** surrounding aperture **18** includes a disproportionately thick portion (*e.g.* septum secundum **16** as compared to septum primum **14**), the offset **A** may be used to seat occluder **20** more securely upon septal tissue **12**. Moreover, the offset **A** allows each of sides **30** and **40** to be centered around each side of an asymmetric aperture **18**.

[0061] When a central tube 22 at angle θ is included in occluder 20, a marker is required to properly orient the occluder 20 in its intended *in vivo* delivery location. For example, platinum wire may be wrapped around one of loops 32 or 42 so as to permit visualization of the orientation of the occluder 20 using fluoroscopy.

5 Alternatively, other types of markers may be used, *e.g.* coatings, clips, etc. As one skilled in the art would appreciate, the radiopaque marker could be blended in with the extrudate and thus provide visibility under fluoroscopy. As will be readily understood by one skilled in the art, the orientation of a non-symmetrical occluder 20 during delivery is of great importance. Of course, when a non-symmetrical occluder
10 20 is used, the periphery of the occluder 20 may be configured such that the clamping force applied by the proximal side 40 is directly opposed to that applied by the distal side 30.

[0062] Upon deployment *in vivo* (a process described in detail below), an occluder 20 according to the present invention applies a compressive force to the
15 septal tissue 12. Distal side 30 is seated against the septal tissue 12 in the left atrium 13; central tube 22 extends through the aperture 18; and proximal side 40 is seated against the septal tissue 12 in the right atrium 11. At least some portion of each of loops 32 and 42 contacts septal tissue 12. In particular embodiments, a substantial length of each of loops 32 and 42 contacts septal tissue 12. As illustrated in the
20 representative Figures, the proximal side 40 and distal side 30 of occluder 20 overlap significantly, such that the septal tissue 12 is “sandwiched” between them once the occluder 20 is deployed. According to at least some embodiments and depending upon the material used to form occluder 20, the loops 32 and 42 provide both a radially-extending compressive force and a circumferential compressive force to
25 septal tissue 12. In these embodiments, the compressive forces are more evenly and more widely distributed across the surface of the septal tissue 12 surrounding the aperture 18 and, therefore, provide the occluder 20 with superior dislodgement resistance as compared to prior art devices. As used in this application, “dislodgement resistance” refers to the ability of an occluder 20 to resist the tendency
30 of the force applied by the unequal pressures between the right 11 and left 13 atria (*i.e.* the “dislodging force”) to separate the occluder 20 from the septal tissue 12. Generally, a high dislodgement resistance is desirable.

[0063] Loops **32** and **42** are also configured to minimize the trauma they inflict on the septal tissue **12** surrounding aperture **18**. Specifically, as indicated previously, the outer perimeter of loops **32** and **42** may be rounded. Accordingly, occluder **20** has a low compression resistance. For example, as illustrated in Figures 2B-2D, the circumferential portions of loops **32** and **42** are thinner than the orthogonally-
5 extending portions of loops **32** and **42**; therefore, the center of the occluder **20** is stronger than its perimeter. As used in this application, "compression resistance" refers to the ability of an occluder **20** to resist the lateral compressive force applied by the heart as it contracts during a heartbeat. Generally, an occluder that resists
10 compressive force, *i.e.* has high compression resistance, is undesirable because its rigid shape and arrangement may cause trauma to the septal tissue **12**, the right atrium **11**, and/or the left atrium **13**.

[0064] According to at least some embodiments of the present invention, occluder **20** further includes a catch system, generally indicated at **131**, that secures the
15 occluder **20** in its deployed state. The catch mechanism **131**, in general, maintains the shape and arrangement of occluder **20** once the occluder **20** has been deployed. Catch system **131** reduces and maintains the axial length L of the occluder **20** so that occluder **20** maintains its deployed state, is secured in the aperture **18**, and consistently applies a compressive force to septal tissue **12** that is sufficient to close
20 aperture **18**. Catch system **131** is particularly advantageous when the occluder **20** is formed of a polymeric material, as previously described, because the polymeric occluder **20** may be deformed during delivery such that it may not fully recover its intended shape once deployed. By reducing and maintaining the axial length L of occluder **20** once it has been deployed *in vivo*, catch mechanism **131** compensates for
25 any undesirable structural changes suffered by occluder **20** during delivery. In some embodiments, catch system **131** includes a ceramic material or a material selected from the group consisting of metals, shape memory materials, alloys, polymers, bioabsorbable polymers, and combinations thereof. In particular embodiments, the catch system may include nitinol or a shape memory polymer. Further, the catch
30 system may include a material selected from the group consisting of Teflon-based materials, polyurethanes, metals, polyvinyl alcohol (PVA), extracellular matrix

(ECM) or other bioengineered materials, synthetic bioabsorbable polymeric scaffolds, collagen, and combinations thereof.

[0065] Catch system **131** may take a variety of forms, non-limiting examples of which are provided in Figures 6A-6E. For example, as shown in Figure 6A, catch system **131** includes two members, *e.g.*, balls, **133** and **135** attached to delivery string **137**. The catch system and catch element are preferably the same material as the occluder, although based on design selection, they could be the same or different material. In certain circumstances, it may be necessary to make them of different material. Delivery string **137** is permanently attached to member **135** and is then threaded through end **39**, distal portion **30** of tube **25**, central tube **22**, proximal portion **40** of tube **25**, and tip **44**, such that ball **133** is located between central tube **22** and end **39** and ball **135** is located on the distal side of end **39**. The function of catch system **131** is shown in Figures 6B-6E. Ball **133** is designed such that, upon the application of sufficient pulling force F_1 to delivery string **137**, it passes through central tube **22** (Figure 6B) and tip **44** (Figure 6C). Ball **133** cannot reenter tip **44** or central tube **22** without the application of a sufficient, additional force. In this manner, ball **133** may be used to bring together the distal side **30** and the proximal side **40**, thereby reducing and maintaining the axial length L of occluder **20**. Obviously, during the application of pulling force F_1 , the tip **44** of occluder **20** must be held against an object, such as a delivery sheath. Ball **135** is designed such that, upon application of sufficient pulling force F_2 to delivery string **137**, it passes through end **39** (Figure 6D) and central tube **22** (Figure 6E). The pulling force F_2 required to move ball **135** through end **39** and central tube **22** is greater than the pulling force F_1 required to move ball **133** through central tube **22** and tip **44**. However, ball **135** cannot pass through tip **44**. Thus, the application of sufficient pulling force F_2 to ball **135** releases distal side **30** and proximal side **40**, as described in more detail below. It should be noted that while members **133** and **135** are illustrated as spherical members in Figures 6A-6E, members **133** and **135** may take any suitable shape. For example, members **133** and **135** may be conical. The narrow portions of conical members **133** and **135** point toward tip **44** of proximal side **40**. One possible mode of recovery or retrieval for this device is simply reversing the implantation procedure. Of course,

other modes of recovery or retrieval are possible, some of which are described in this specification.

[0066] A different system for securing the device in the deployed state is shown in Figures 7A-7C. A locking mechanism **191** includes a hollow cylinder **141** having at least two half-arrows **143** and **145** located at its proximal end (Figure 7A).

Cylinder **141** enters tip **44** under application of pulling force F_1 to delivery string **137**. As cylinder **141** enters tip **44**, half-arrows **143** and **145** are forced together such that the diameter of the proximal end of cylinder **141** is reduced (Figure 7B). Under continued application of pulling force F_1 , half-arrows **143** and **145** pass through tip **44** and expand to their original shape and arrangement (Figure 7C). Given that half-arrows **143** and **145** extend beyond the diameter of tip **44**, the axial length of an occluder **20** including the locking mechanism **191** shown in Figures 7A-7C is maintained in its reduced state. If the implant needs to be removed or repositioned, the locking mechanism **191** shown in Figures 7A-7C may be released by moving half-arrows **143** and **145** together such that the diameter of the proximal end of cylinder **141** is smaller than that of tip **44** and cylinder **141** passes through tip **44**. Cylinder **141** may then be withdrawn from tip **44**.

[0067] One skilled in the art will recognize that catch system **131** may assume numerous configurations while retaining its capability to reduce and maintain the axial length L of occluder **20** such that occluder **20** maintains its deployed state. For example, catch system **131** may include a threaded screw, a tie-wrap, or a combination of catch systems **131**. Furthermore, catch system **131** may include multiple members that may provides a stepped deployment process. For example, catch system **131** as depicted in Figures 6A-6E may include three balls. In this configuration, one ball is used to secure the distal end **30** of occluder **20** and another ball is used to secure the proximal end **40** of occluder **20**, and the third ball is secured to the distal end. Any suitable catch system **131** may be incorporated into any of the embodiments of occluder **20** described herein. One skilled in the art will be capable of selecting the catch system **131** suitable for use in a given clinical application.

[0068] Occluder **20** may be modified in various ways. According to some embodiments of the present invention, distal side **30** and/or proximal **40** side of occluder **20** may include a tissue scaffold. The tissue scaffold ensures more complete

coverage of aperture **18** and promotes encapsulation and endothelialization of septal tissue **12**, thereby further encouraging anatomical closure of the septal tissue **12**. The tissue scaffold may be formed of any flexible, biocompatible material capable of promoting tissue growth, including but not limited to polyester fabrics, Teflon-based materials, ePTFE, polyurethanes, metallic materials, polyvinyl alcohol (PVA),
5 extracellular matrix (ECM) or other bioengineered materials, synthetic bioabsorbable polymeric scaffolds, other natural materials (*e.g.* collagen), or combinations of the foregoing materials. For example, the tissue scaffold may be formed of a thin metallic film or foil, *e.g.* a nitinol film or foil, as described in United States Patent
10 Appl. No. 2003/0059640 (the entirety of which is incorporated herein by reference). In those embodiments where occluder **20** includes a tissue scaffold, the scaffold may be located on the outside the face of distal side **30** with an alternative of including scaffold also inside the proximal side **40**. Also, the tissue scaffold could be disposed against the tissue that is sought to be occluded, such as the septal tissue **12** so that the
15 proximity of the tissue scaffold and septal tissue **12** promotes endothelialization. Loops **32** and **42** may also be stitched to the tissue scaffold to securely fasten the scaffold to occluder **20**. One skilled in the art will be able to determine those clinical applications in which the use of tissue scaffolds and/or stitches is appropriate.

[0069] Occluder **20** may be further modified so that it lacks end **39** and tip **44**, as
20 shown in Figures 8A-8C, and, therefore, has a reduced septal profile. Such an occluder may be formed in several ways. For example, according to one embodiment, slits **31** and **41** are extended through end **39** and tip **44**, respectively, of tube **25** during the cutting process. This cutting pattern produces struts **32** that deform during deployment to produce incomplete loops **32**. One side of the device, facing the
25 viewer as shown in Figure 8A, is formed by slits **31** that extend along the tube **25** to varying lengths. The tube **25** is cut in half to form half sections **154a** and **154b**. The half sections **154a** and **154b** are further cut to a proximal distance from the end **39** into quarter sections **155a**, **156a**, **155b**, and **156b**. The ends of the quarter sections **155a** and **155b** are joined at "free ends" **153** to close the loop **32**. Similarly, the free
30 ends of quarter sections **156a** and **156b** may be joined by appropriate cutting, see Fig. 8b. The ends may be joined using any suitable connectors, *e.g.*, **151**, *e.g.*, welds. One of skill in the art will recognize that the free ends **153** of loops **32** may be connected

using other means, including but not limited to seams and bonds obtained by heat or vibration.

[0070] In the above embodiment, the slits in the quarter sections are run completely through the end of the tube **39**. In an alternative embodiment, the end **39**
5 may remain uncut, thereby eliminating the need for a weld to join the quarter sections together.

[0071] The embodiment illustrated in Figures 8A-8C depicts an occluder **20** in which both sides are formed according to the above-described design. Alternatively, an occluder **20** according to the present invention may include a hybrid structure,
10 wherein one side is designed according to the embodiment shown in Figures 8A-8C and the other side is designed according to other types of structures disclosed in this application.

[0072] Occluder **20** may be prepared for delivery to an aperture **18** in any one of several ways. Slits **31** and **41** may be cut such that tube **25** bends into its intended
15 configuration following deployment *in vivo*. Specifically, slits **31** and **41** may be cut to produce struts **32** and **42** of a thickness that facilitates the bending and formation of loops **32** and **42** upon the application of forces F_d and F_p during deployment. Alternatively and/or additionally, a tube **25** formed of a shape memory material may be preformed into its intended configuration *ex vivo* so that it will recover its
20 preformed shape once deployed *in vivo*. According to at least some embodiments, this preforming technique produces more reliable deployment and bending of occluder **20** *in vivo*. An intermediate approach may also be used: tube **25** may be only slightly preformed *ex vivo* such that it is predisposed to bend into its intended shape *in vivo* upon application of forces F_d and F_p .

[0073] An occluder **20** as described herein may be delivered to an anatomical aperture **18** using any suitable delivery technique. For example, distal side **30** and proximal side **40** of occluder **20** may be deployed in separate steps, or both distal side **30** and proximal side **40** of occluder **20** may be deployed prior to engaging the catch system. One delivery method will be described in detail herein. As shown in Figures
30 9A-9H, a delivery sheath **161** containing pusher sleeve **169** (shown in Fig. 9H) is used to deliver occluder **20** including the catch system **131** illustrated in Figures 6A-6E. Sheath **161** contains occluder **20** in its elongated, delivery form (Figure 9A). As

shown in Figure 9B, delivery sheath **161** is first inserted into the right atrium **11** of the patient's heart. Sheath **161** is next inserted through aperture **18** located in the septal tissue **12** (which, in this example, is a PFO tunnel) and into the left atrium **13** (Figure 9C). Distal side **30** of occluder **20** is then deployed into the left atrium **13**, as shown
5 in Figure 9D. Following deployment of distal side **30**, pulling force F_1 is applied to delivery string **137** such that ball **133** passes through the central tube **22**, thereby securing distal side **30** into its deployed state (Figure 9E). Sheath **161** is withdrawn through the aperture **18** and into the right atrium **11**, such that central tube **22** is deployed through the aperture **18** (Figure 9F). Proximal side **40** of occluder **20** is then
10 deployed into the right atrium **11** (Figure 9G), and pulling force F_1 is again applied to delivery string **137** such that ball **133** passes through tip **44**, thereby securing the proximal side **40** into its deployed state (Figure 9H). When properly deployed, occluder **20** rests within the aperture **18**, and the distal side **30** and proximal side **40** exert a compressive force against septum primum **14** and septum secundum **16** in the
15 left **13** and right **11** atria, respectively, to close the aperture **18**, *i.e.* the PFO. When occluder **20** is properly deployed, delivery string **137** is detached from catch system **131**, including balls **133** and **135** and a connecting member, and sheath **161** is then withdrawn from the heart. In the event occluder **20** is not properly deployed after performing the procedure described above, the occluder **20** may be recovered by
20 reversing the steps of the delivery sequence.

[0074] In the an alternative recovery technique, the occluder **20** may be recovered and repositioned by catch system **131** as shown in Figures 10A-10D. Pusher sleeve **169** in sheath **161** is positioned against tip **44** in the right atrium **11** (Figure 10A). Pulling force F_2 is applied to delivery string **137**, such that ball **135** passes through
25 end **39** and into central tube **22**, thereby releasing distal side **30** from its deployed state (Figure 10B). Force F_2 is again applied to delivery string **137** so that ball **135** subsequently passes through central tube **22**, thereby releasing proximal side **40** from its deployed state (Figure 10C). Delivery string **137** is then pulled further such that occluder **20**, now in its elongated state, is retracted into sheath **161** (Figure 10D).
30 Following recovery of occluder **20**, sheath **161** may be withdrawn from the heart and another occluder inserted in the desired delivery location as described above and shown in Figures 9A-9H.

[0075] Distal side **30** and proximal side **40** are connected by central tube **22**. As illustrated, the central tube **22** is an uncut central part of the tube used to form occluder **20**. As described below, the entire tube is indicated by reference numeral **25**. As shown, the occluder **20** may be inserted into the septal tissue **12** to prevent the
5 flow of blood through the aperture **18a**, *e.g.*, the occluder may extend through the PFO tunnel such that the distal side **30** is located in the left atrium **13** and the proximal side **40** is located in the right atrium **11**. Additionally or alternatively, the occluder **20** may be inserted into the septal tissue **12** so as to prevent the flow of blood through the aperture **18b**, *e.g.*, the occluder may extend through the ASD such that the
10 distal side **30** is located in the left atrium **13** and the proximal side **40** is located in the right atrium **11**. As used in this application, unless otherwise indicated, the term “aperture **18**” refers to any anatomical anomaly that may be treated by use of occluder **20**, such as PFO **18a** or ASD **18b**.

[0076] The occluder **20** is constructed of one or more metal or polymer tube(s),
15 referred to collectively as “tube” **25**. Tube **25** includes slits **31** and **41**, which are formed using an etching or cutting process that produces a particular cutting pattern on tube **25**. For example, as shown in Figure 11C, slits **31** are cut along the axial length of the upper half of tube **25** using a cutting tool, *e.g.*, a razor blade. According to some embodiments of the present invention and as shown in Figure 11C, slits **31**
20 are cut without removing any significant amount of material from tube **25**, *i.e.*, the formation of slits **31** does not significantly reduce the overall volume of tube **25**. According to other embodiments of the present invention, slits **31** are formed by cutting material out of tube **25** such that the volume of tube **25** is reduced. Both ends of each of slits **31** are rounded so as to relieve stresses at the axial ends of the slits **31**.
25 This prevents slits **31** from lengthening due to cyclic stresses present in a beating heart and the resultant material fatigue. In those embodiments where slits **31** are cut without removing any significant amount of material from tube **25**, rounded ends or holes **33** may be produced by burning holes at both ends of each of slits **31**. In those embodiments where slits **31** are formed by cutting material out of tube **25**, rounded
30 ends **33** may be formed during the cutting process. The size of rounded ends **33** may vary depending upon the dimensions of tube **25** and the amount of stress release required by the deformation.

[0077] As shown in Figures 11A-11C, cutting slits **31** forms struts **32** in tube **25**. Upon deployment, struts **32** deform into a shape generally characterized as “loops” **32**. Thus, the number of slits **31** cut in the upper half of tube **25** according to the foregoing process is n_d , where n_d is the number of loops **32** ultimately desired in distal side **30** when occluder **20** is deployed. Thus, four slits **31** are cut in the upper portion of tube **25** to produce four struts **32a**, **32b**, **32c**, and **32d** (Figures 11A-11C).

[0078] Upon the application of force F_d to distal end **39** of tube **25**, the axial ends of slits **31** are brought together such that struts **32** bow radially outwardly to form loops **32** of distal side **30**. Central tube **22** may be constrained during the application of force F_d . One skilled in the art will recognize that any combination of forces sufficient to reduce the axial length of the tube **25** would be sufficient to deploy the distal side **30** of occluder **20**. The cross-sectional dimensions of loops **32** are determined by the thickness of tube **25** and the distance between adjacent slits **31**.

The length of slits **31** determines the length of loops **32** and the radial extent of the deployed occluder **20**. In this manner, the dimensions of loops **32** may be controlled during production of occluder **20**. For example, as more material is removed from tube **25** during the cutting process used to form slits **31**, the thickness of loops **32** decreases. Moreover, any or all of slits **31** may be cut such that struts **32** vary in thickness along their length; accordingly, loops **32** will also vary in thickness along their length. In some embodiments, it may be desirable to have a wider strut **32** at the location where it joins tube **25** to create a sturdier device. Alternatively, it may be desirable to have a wider portion elsewhere along strut **32** such that occluder **20** is predisposed to bend into a certain shape and arrangement. For example, the portion of each of struts **32** nearer central tube **22** may be thinner than the portion of each of struts **32** nearer end **39** to facilitate bending of struts **32** into loops **32** during deployment of occluder **20**.

[0079] Loops **42** in proximal side **40** of occluder **20** are produced by forming slits **41** in the lower half of tube **25** using the same cutting process(es) described above for distal side **30** (Figure 11B). The cutting of slits **41** produces struts **41** in tube **25** (Figures 11A-11B) that deform into loops **42** in proximal side **40** when occluder **20** is deployed. The number of slits **41** cut in the lower half of tube **25** is n_p , where n_p is the number of loops **42** ultimately desired in proximal side **40** of occluder **20**. Thus, four

slits **41** are cut in the upper portion of tube **25** to produce four struts **42a**, **42b**, **42c**, and **42d** and, ultimately, four loops **42a**, **42b**, **42c**, and **42d** in proximal side **40**.

Although distal side **30** and proximal side **40** may each include the same number of loops **32** and **42**, respectively, there is no requirement that the number of loops **32** is
5 identical to the number of loops **42**, as described in more detail below. When force F_p is applied to end **44** of tube **25**, the axial ends of slits **41** are brought together such that struts **42** bow radially outwardly to form loops **42** of proximal side **40**. As discussed above in the context of deploying distal side **30**, central tube **22** may be constrained during the application of force F_p . One skilled in the art will recognize that any
10 combination of forces sufficient to reduce the axial length of the tube **25** would be sufficient to deploy the proximal side **40** of occluder **20**. The dimensions of loops **42** may be varied as described above for loops **32**.

[0080] Slits **31** and **41**, as shown in Figure 11B, are cut axially along the length of tube **25**. However, as one of skill in the art will recognize, slits **31** and/or **41** may also
15 be cut along other dimensions of tube **25**. For example, as shown in Figure 11A, slits **31** and **41** may be cut at an angle such that they are helically disposed on tube **25**.

Angled slits **31** and **41** produce angled struts **32** and **42**, which deform into angled loops **32** and **42** during deployment. Further, slits **31** and **41** need not be straight; for example, slits **31** and **41** may be cut as zigzags, S-shaped slits, or C-shaped slits. One
20 skilled in the art will be capable of selecting the angle for the slits **31** and/or **41** and the loop **32** and **42** shape(s) appropriate for a given clinical application. For example, when occluder **20** is formed from a polymer tube **25**, straight loops **32** and **42** may be preferable because they will impart maximum stiffness to occluder **20**. If the tube **25** is formed of a stiffer material, the angled slits **31** and/or **41** may provide a more
25 desired stiffness to the occluder **20**.

[0081] One skilled in the art will recognize that the occluders described herein may be used with anti-thrombogenic compounds, including but not limited to heparin and peptides, to reduce thrombogenicity of the occluder and/or to enhance the healing response of the septal tissue **12** following deployment of the occluder *in vivo*.

30 Similarly, the occluders described herein may be used to deliver other drugs or pharmaceutical agents (*e.g.* growth factors, peptides). The anti-thrombogenic compounds, drugs, and/or pharmaceutical agents may be included in the occluders of

the present invention in several ways, including by incorporation into the tissue scaffold, as previously described, or as a coating, *e.g.* a polymeric coating, on the tube(s) **25** forming the distal side **30** and proximal side **40** of the occluder **20**.

5 Furthermore, the occluders described herein may include cells that have been seeded within the tissue scaffold or coated upon the tube(s) **25** forming the distal side **30** and proximal side **40** of the occluder **20**.

[0082] One skilled in the art will further recognize that occluders according to this invention could be used to occlude other vascular and non-vascular openings. For example, the device could be inserted into a left atrial appendage or other tunnels or
10 tubular openings within the body.

[0083] Having described preferred embodiments of the invention, it should be apparent that various modifications may be made without departing from the spirit and scope of the invention, which is defined in the claims below.

What is claimed is:

1. An occluder for a defect adapted to be introduced into the body through the vasculature, the occluder having a proximal side and a distal side that cooperate to close the defect, at least one of the proximal and distal sides of the occluder including
5 slits axially formed in the tube to form struts, wherein adjacent slits are offset and the struts form petals when the axially length of the tube is shortened.
2. The occluder according to claim 1 wherein the slits in the occluder extend along an line parallel to the axis of the tube.
3. The occluder according to claim 1 wherein the slits in the occluder extend
10 along a helical line along the tube.
4. The occluder of claim 1 wherein a catch system is adapted to secure the occluder in a deployed position such that the occluder is not secured during delivery and becomes secured in its delivery profile during the delivery process.
5. The occluder of claim 4 wherein the catch system comprises catch elements
15 that cooperate with a passageway within the occluder such that occluder becomes secured in a deployed state when a portion of the occluder tube is positioned between the catch elements.
6. The occluder of claim 5 wherein the catch elements are balls.
7. The occluder of claim 1 wherein the both the proximal side of the occluder
20 and the distal side of the occluder have loops formed by struts and the occluder is

adapted to be secured in the heart with tissue between the proximal side and the distal side of the occluder.

8. The occluder of claim 1 wherein a locking member comprises two locking pieces which are adapted to hold the occluder in the deployed state when the locking
5 pieces cooperate with the central member of the occluder.
9. The occluder of claim 1 wherein the occluder includes a central portion and the central portion is angled with respect to the plane of the loops of the occluder in the deployed state.
10. The occluder of claim 9 wherein the angle between the central tube and
10 occluder in the deployed state is not approximately 90 degrees.
11. The occluder of claim 1 wherein the occluder further comprises tissue scaffolding attached to the loops.
12. The occluder of claim 1 wherein the loops are formed by slits in a tube and the loops have varying cross section because of the offset slits.
- 15 13. An occluder for a defect comprising a tube adapted to be introduced into the body through the vasculature, the occluder having a proximal side and a distal side that cooperate to close the defect, at least one of the proximal and distal sides include an arrangement of struts according to the pattern: n struts for a first axial distance, $2n$ slits for a second axial distance, and n struts for a third axial distance, whereby loops
20 are formed from the struts by the axial shortening of the tube.

14. The occluder of claim 13 wherein the first, second and third axial distances are approximately the same.
15. The occluder of claim 13 wherein the second axial distance is greater than either the first or the second axial distance.
- 5 16. The occluder of claim 13 wherein the both the proximal side of the occluder and the distal side of the occluder have loops formed by struts and the occluder is adapted to be secured in the heart with tissue between the proximal side and the distal side of the occluder.
17. The occluder of claim 16 wherein a catch element is adapted to secure the
10 occluder in a deployed position such that the occluder is not secured during delivery and becomes secured during the delivery process.
18. The occluder of claim 16 wherein the catch system comprises balls that cooperate with a passageway within the occluder such that occluder becomes secured in a deployed state when a portion of the occluder tube is positioned between the
15 balls.
19. The occluder of claim 13 further comprising a locking member that includes at least two locking pieces which are adapted to hold the occluder in the deployed state when the locking pieces cooperate with the central member of the occluder.
20. The occluder of claim 13 wherein the occluder includes a central portion and
20 the central portion is angled with respect to the plane of the loops of the occluder in the deployed state.

21. The occluder of claim 13 wherein the angle between the central tube and occluder in the deployed state is not approximately 90 degrees.
22. The occluder of claim 13 wherein the occluder further comprises tissue scaffolding attached to the loops.
- 5 23. The occluder of claim 13 wherein the tube is formed of a sheet that is rolled into a tube.
24. The occluder of claim 13 wherein the n is 2 and the tube splits into a hemispherical section and then splits into a quarter section and rejoins to a hemispherical section.
- 10 25. The occluder of claim 13 wherein the loops twist when the axial length of the tube is reduced.
26. An occluder for a defect comprising a tube, a proximal side of the tube adapted to be disposed on the proximal side of the defect and a distal side of the tube adapted to be disposed on the distal side of the defect, a plurality of struts formed
- 15 from the tube on one of the proximal and distal sides of the tube by a series of slits disposed in the tube along an axial direction, wherein the struts have first length that has a cross-section comprising half the tube, a second length that is split into a cross-section of the tube comprising a quarter of the tube and then a third length that is split into a cross-section comprising half of the tube.
- 20 27. The occluder of claim 26 wherein the first, second and third axial distances are approximately the same.

28. The occluder of claim 26 wherein the second axial distance is greater than either the first or the second axial distance.

29. The occluder of claim 26 wherein the both the proximal side of the occluder and the distal side of the occluder have loops formed by struts and the occluder is
5 adapted to be secured in the heart with tissue between the proximal side and the distal side of the occluder.

30. The occluder of claim 29 wherein a catch system is adapted to secure the occluder in a deployed position such that the occluder is not secured in a deployed state during delivery and becomes secured during the delivery process.

10 31. The occluder of claim 30 wherein the catch system comprises catch elements that cooperate with a passageway within the occluder such that occluder becomes locked in a deployed state when a portion of the occluder tube is positioned between the balls.

32. The occluder of claim 31 wherein the catch elements are balls.

15 33. A method for deploying an occluding member that includes a series of loops formed by struts in a tube, the struts being formed by a series of offset slits which are configured to form loops when the axial length of the occluder is shortened, the steps comprising:

a) inserting a catheter into a lumen of the body for delivering the occluder, the
20 catheter including a delivery system,

b) deploying a distal end of the occluder by pulling on the delivery wire so that the distal part of the occluder forms loops which are disposed along a surface around a defect to be occluded,

c) pulling a catch element through an axially central passage of the occluder to
5 lock the distal part of the device in a deployed state,

d) deploying a proximal end of the occluder by pulling on the delivery wire so that the proximal part of the occluder forms loops which are disposed along a second surface around the defect to be occluded,

e) pulling the catch element through an axially central passage of the occluder
10 to secure proximal part of the device in a deployed state, and,

f) disengaging the delivery wire from the occluder and removing the catheter from the delivery location.

34. The method of claim 33 wherein the catch element is a ball and the occluder has a central passage that is configured to secure the ball in the deployed state,
15 wherein, step c) further comprises pulling the ball through the central passage and securing the occluder by adapting the ball and passageway to allow for passage through the central passageway toward the proximal direction and not in the distal direction.

35. The method of claim 33 wherein the catch element is a ball and the occluder
20 has a central passage that is configured to secure the ball in the deployed state, wherein, step e further comprises pulling the ball through the central passage and

securing the occluder by adapting the ball and the passageway to allow for the passage of the ball through the central passageway toward the proximal direction and not in the distal direction.

36. The method of claim 33 wherein the central passageway has multiple
5 diameters so that a force required to pull the ball through the central passageway to secure the device at step c) is different than the force required to pull the ball through the central passageway to lock the device in step e).

37. The method of claim 33 where in the occluder is adapted to be delivered as a PFO closure device.

10 38. The method of claim 33 wherein at least one of the proximal and distal sides of the tube forming the occluder includes slits axially formed in the tube that form struts, wherein adjacent slits are offset and the struts form petals when the axially length of the tube is shortened and the process of deployment includes shortening the tube along its axial length.

15 39. An occluder formed of a tube with slits axially disposed in the tube and extending to the end of the tube, the slits form struts between the slits, wherein when the tube is axially shortened, loops are formed by the struts and the struts are joined at the end to form the loops.

40. The occluder of claim 39 wherein the struts are joined by adhesive.

20 41. The occluder of claim 39 wherein the struts are joined by welding.

42. The occluder of claim 39 wherein the struts have axially facing ends and the axially facing ends are welded together to form the loops.

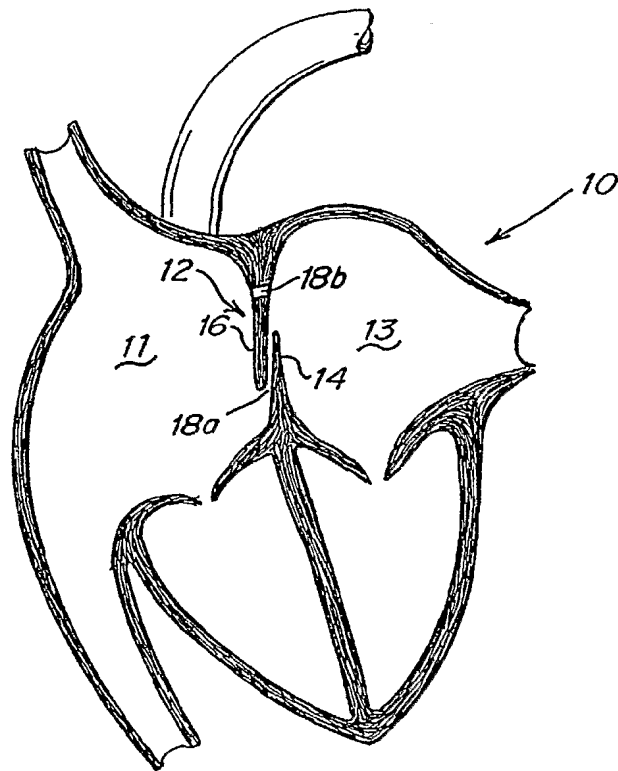

Fig. 1

2/16

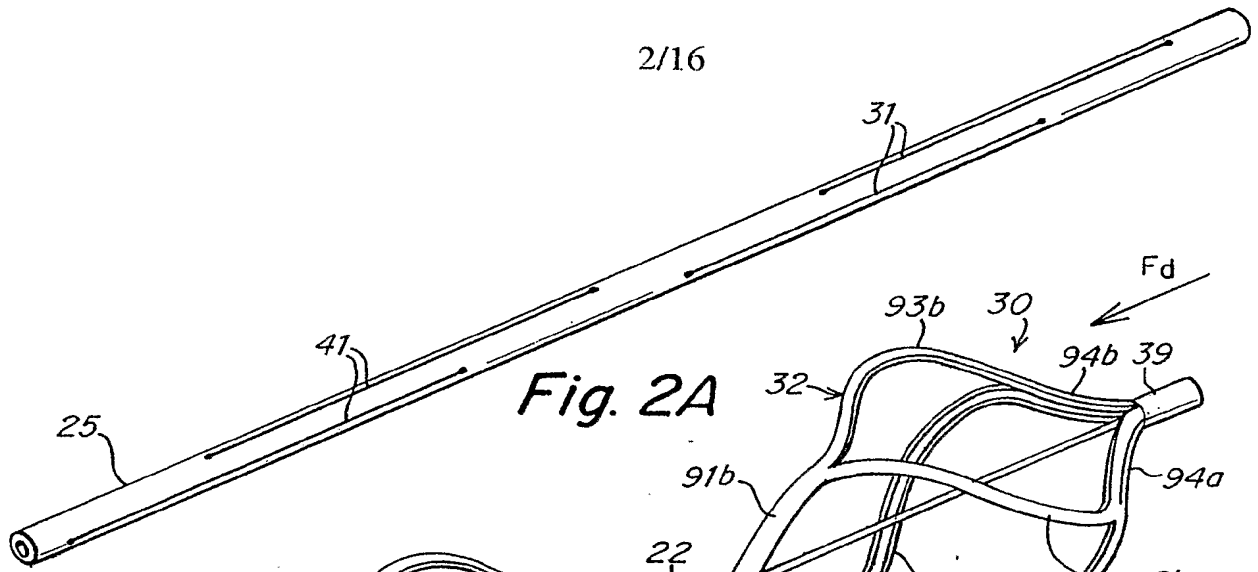

Fig. 2A

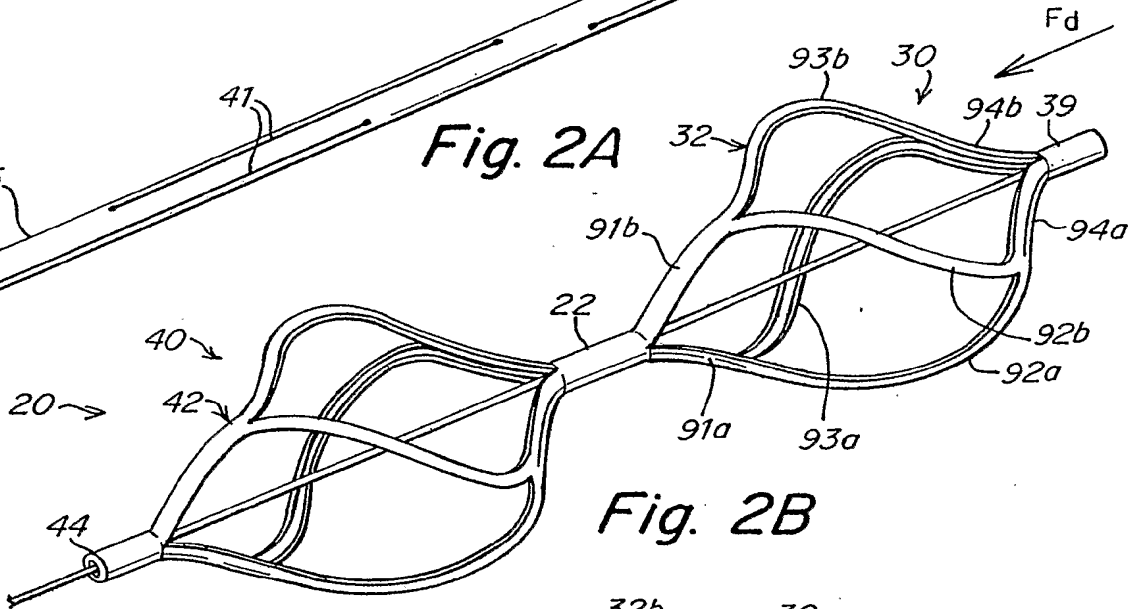

Fig. 2B

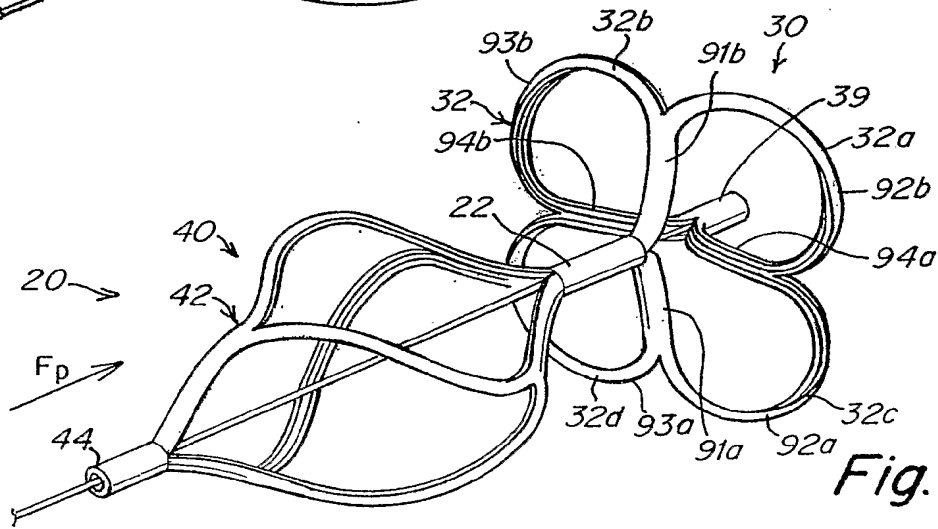

Fig. 2C

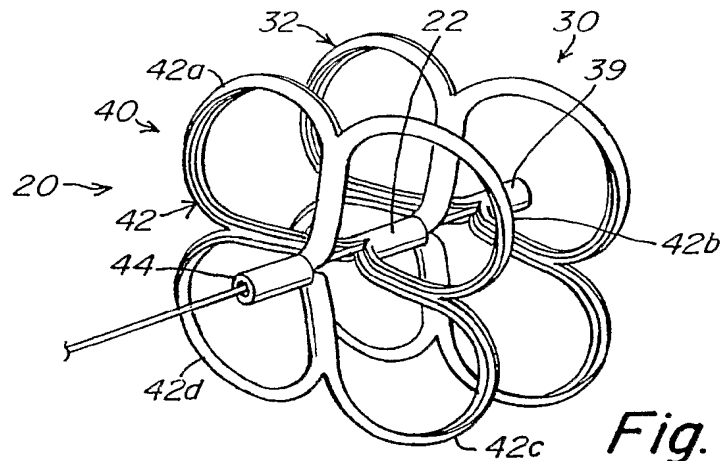

Fig. 2D

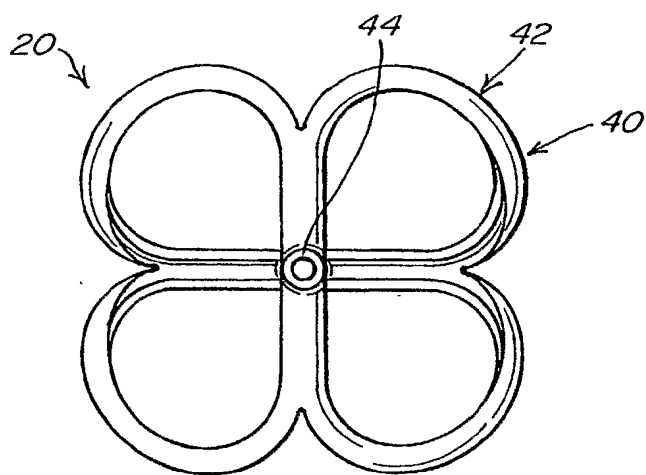

Fig. 3A

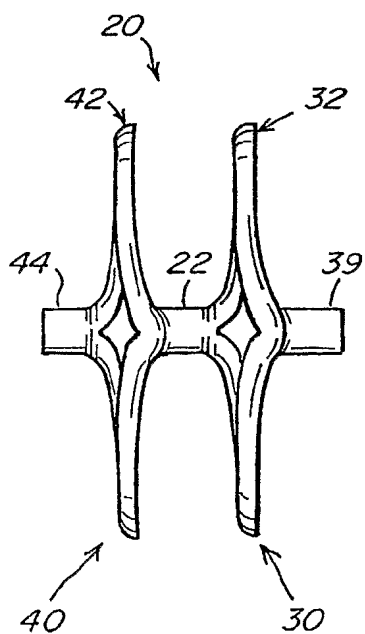

Fig. 3B

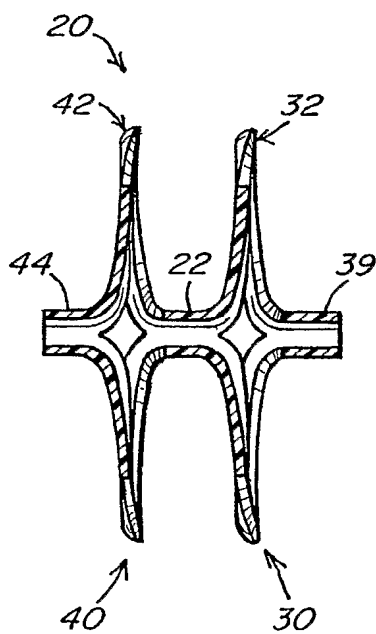

Fig. 3C

4/16

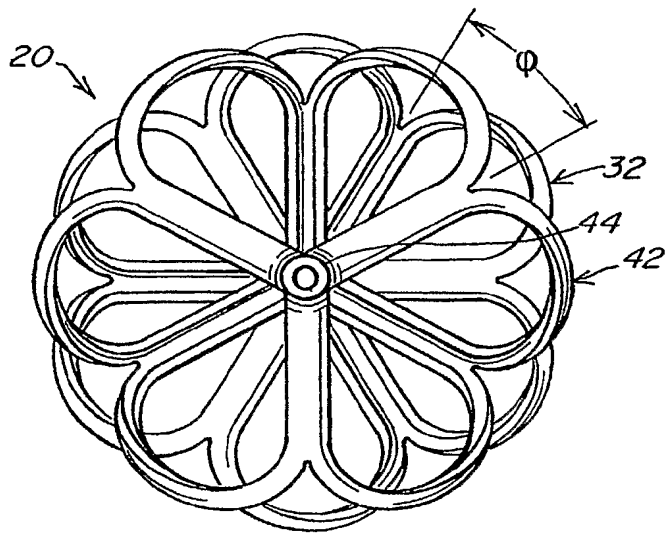

Fig. 4A

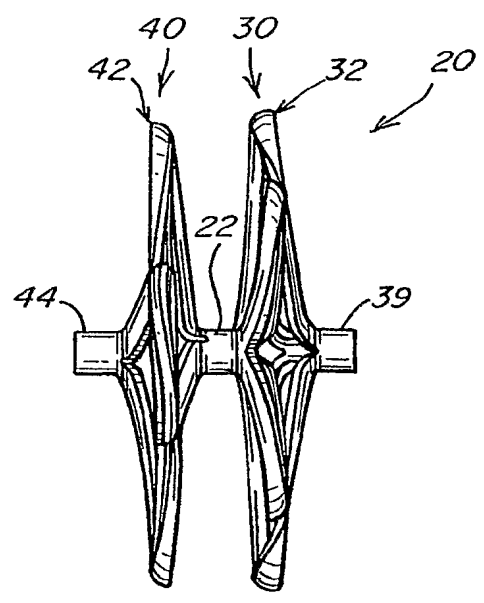

Fig. 4B

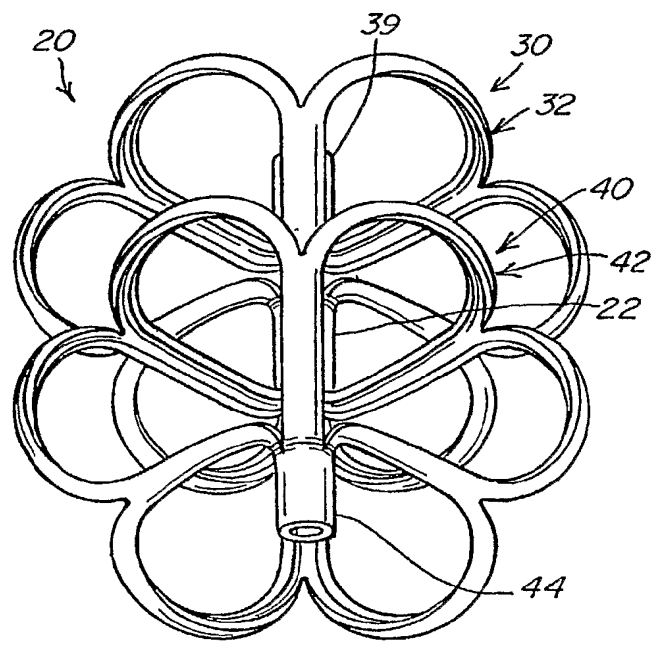

Fig. 5A

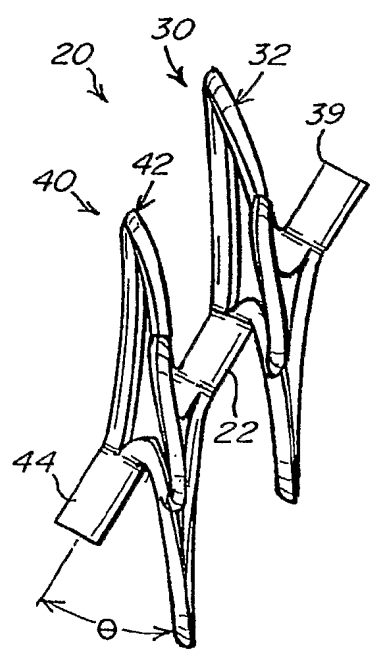

Fig. 5B

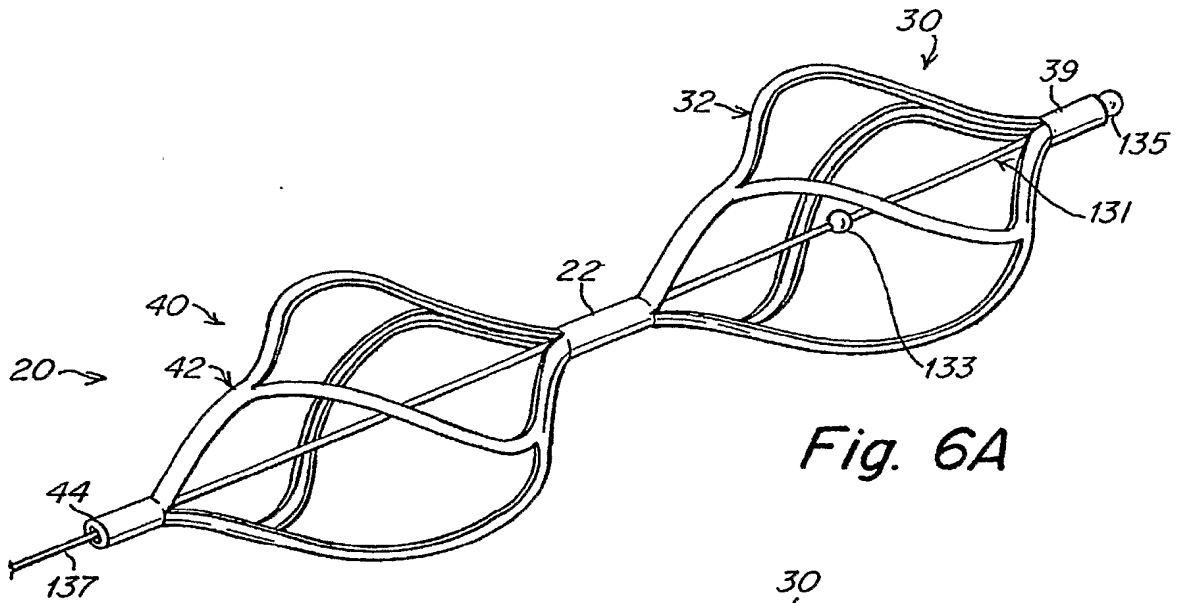

Fig. 6A

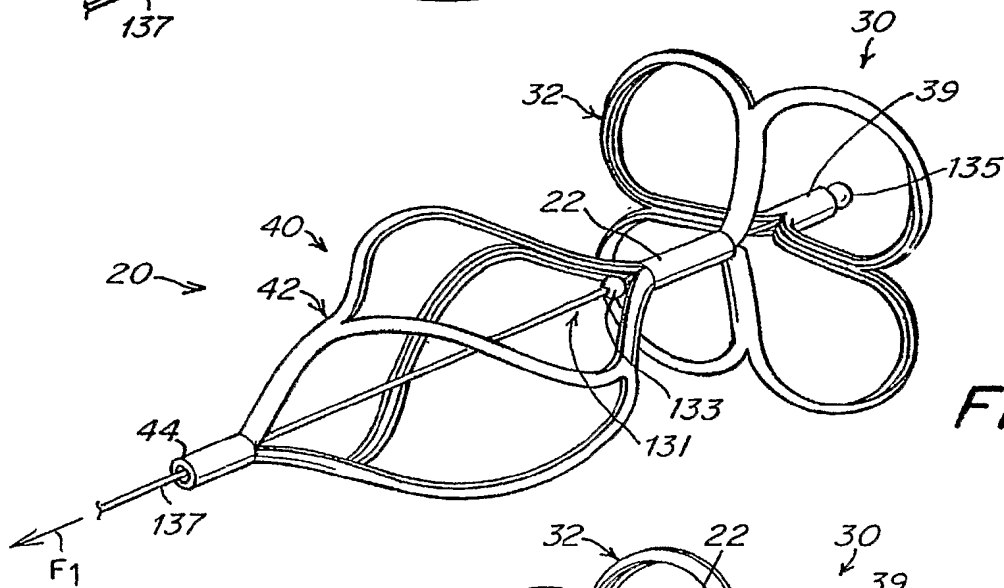

Fig. 6B

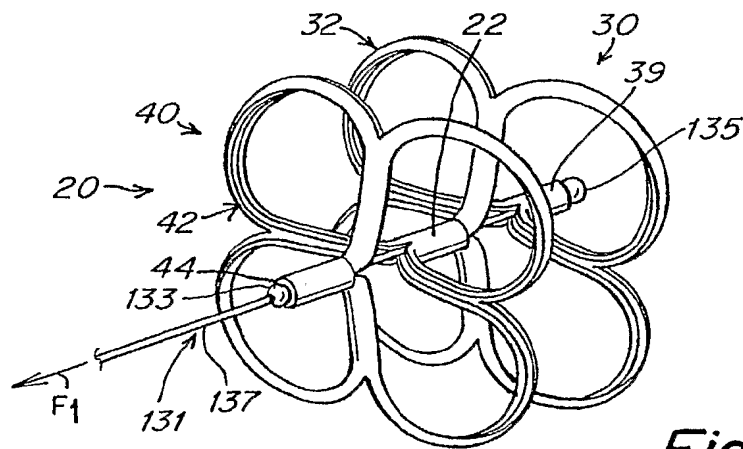

Fig. 6C

6/16

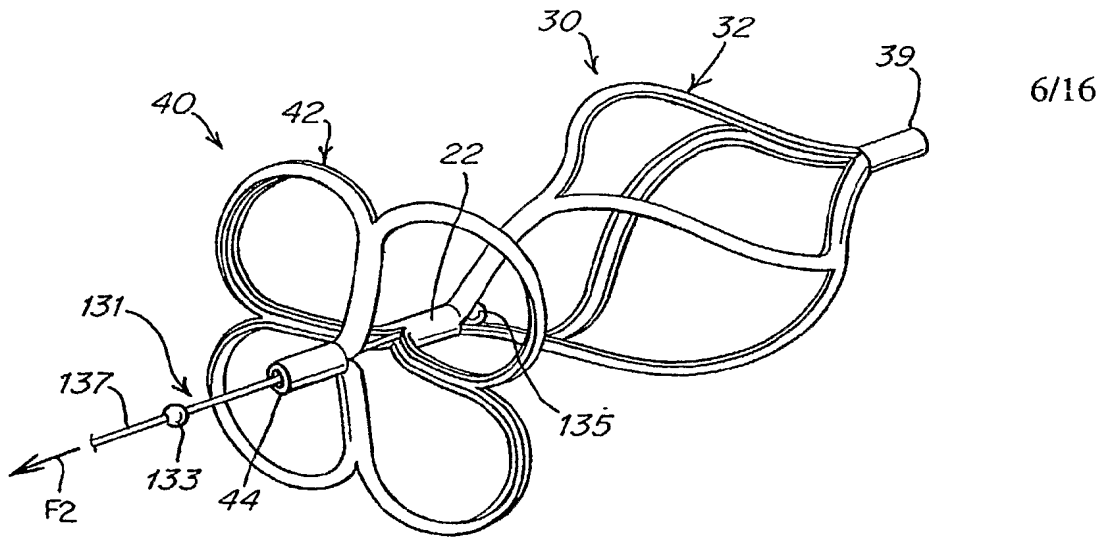

Fig. 6D

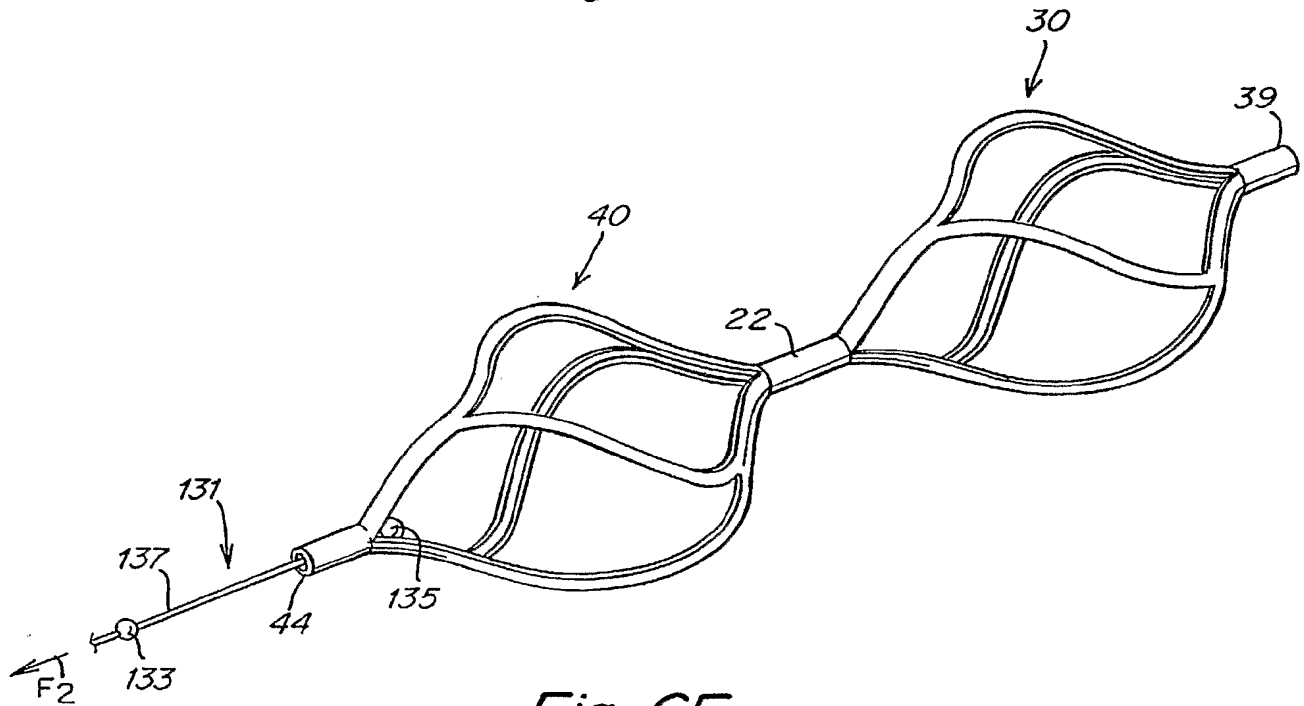

Fig. 6E

7/16

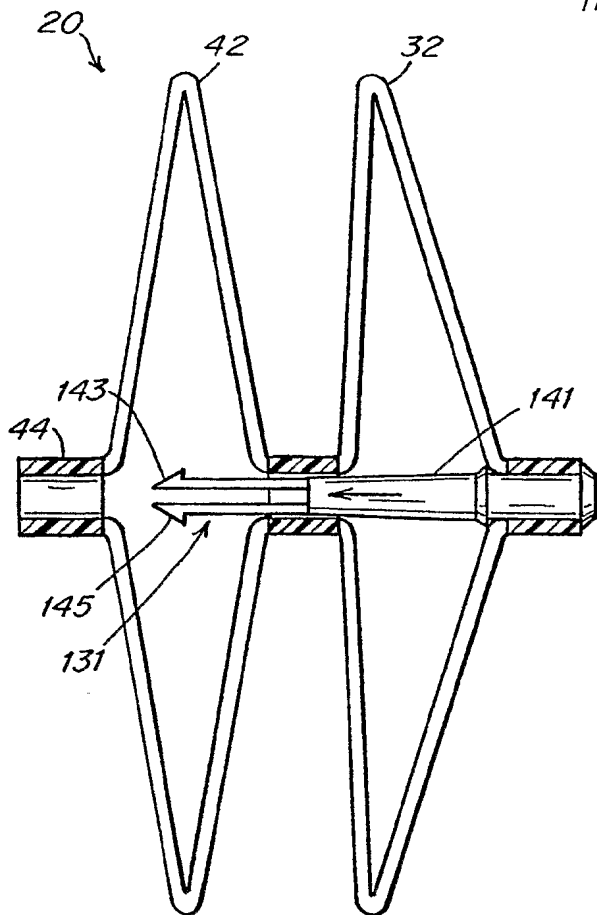

Fig. 7A

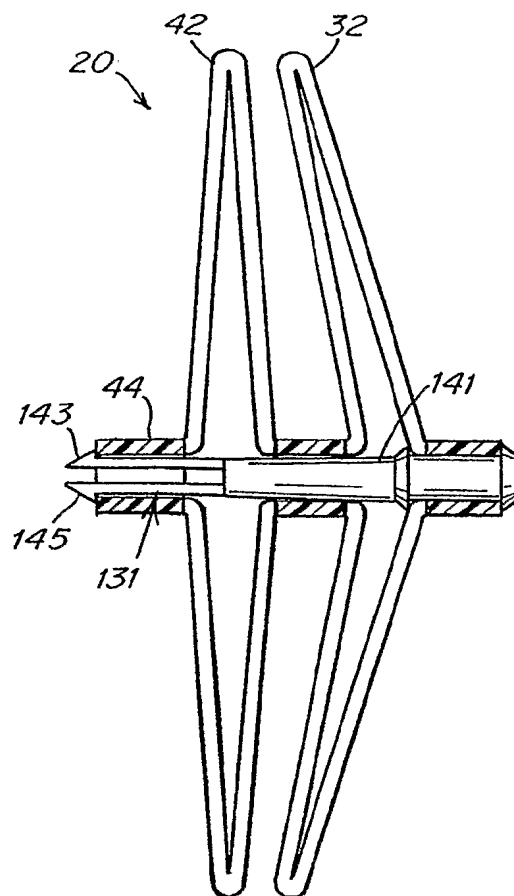

Fig. 7B

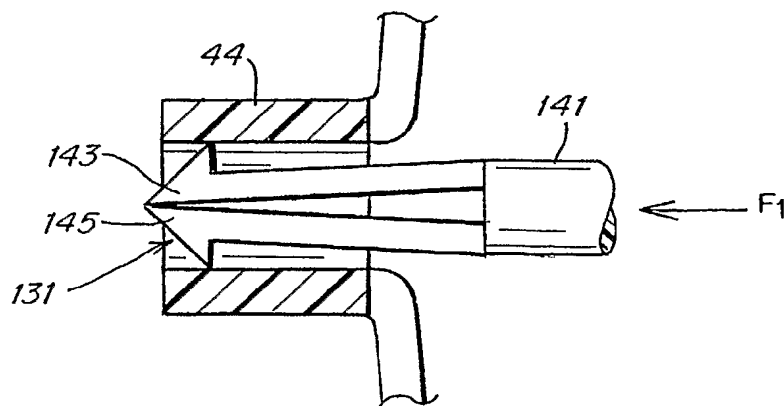

Fig. 7C

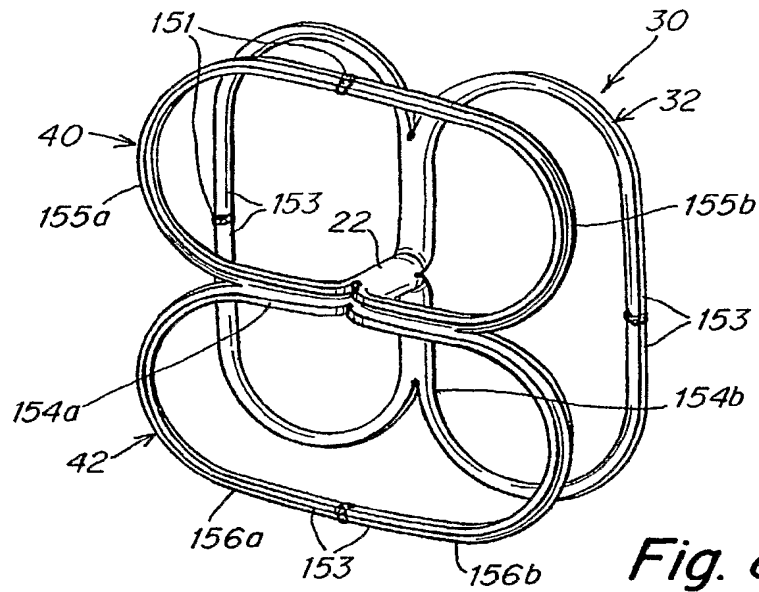

Fig. 8A

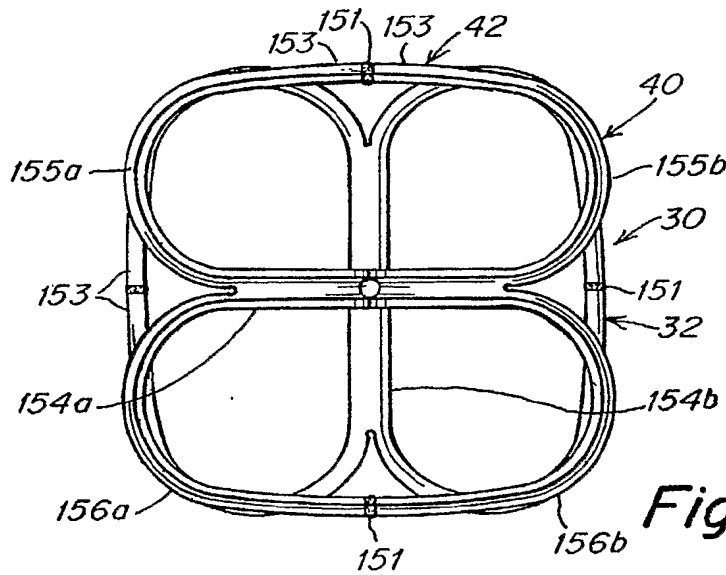

Fig. 8B

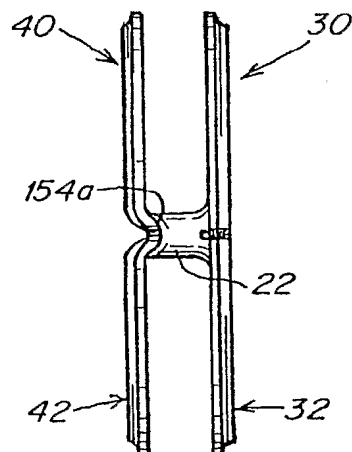
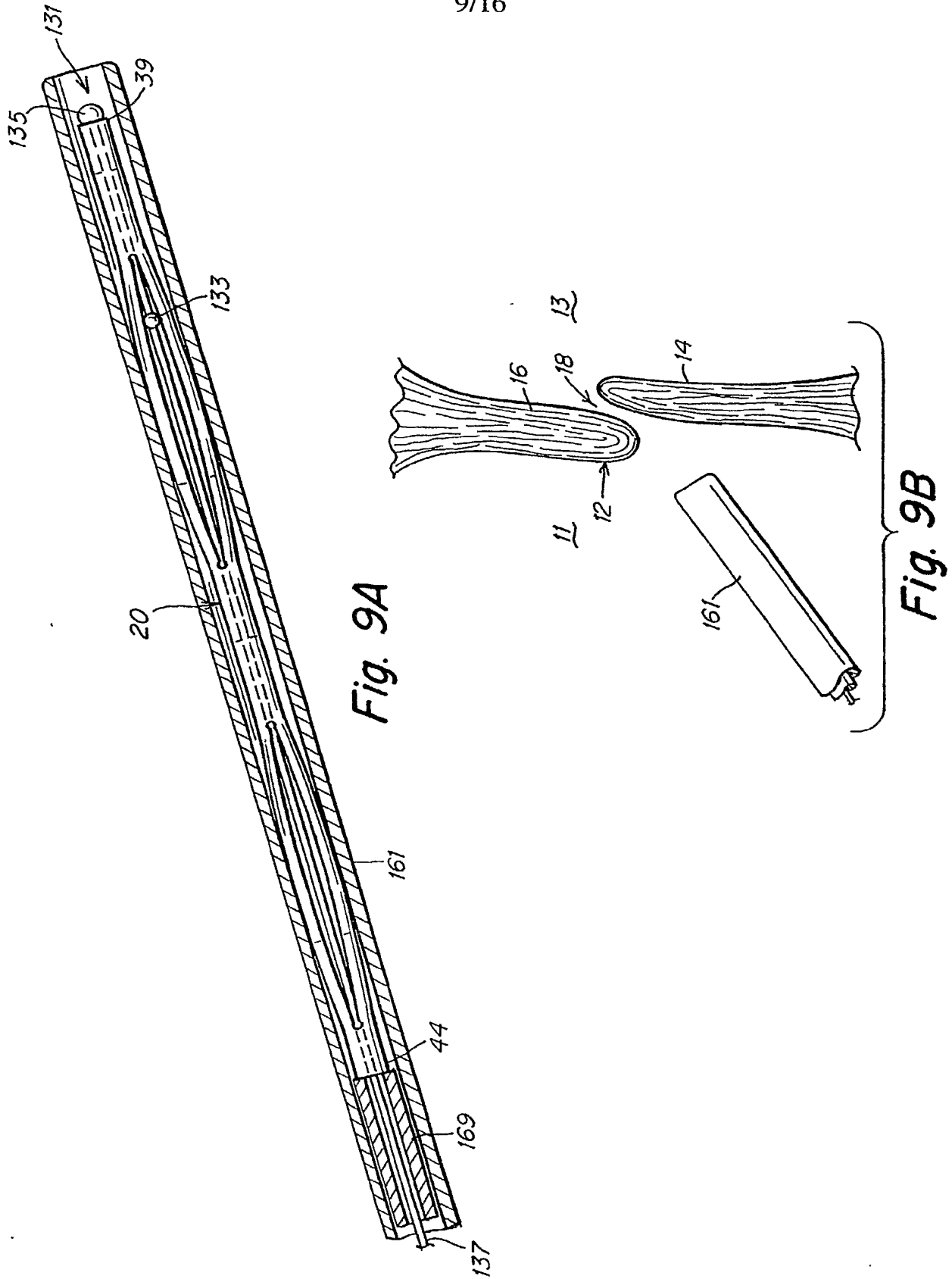

Fig. 8C



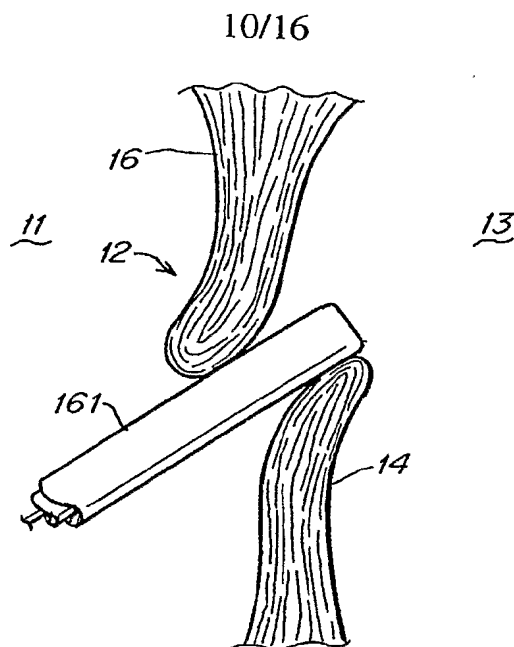

Fig. 9C

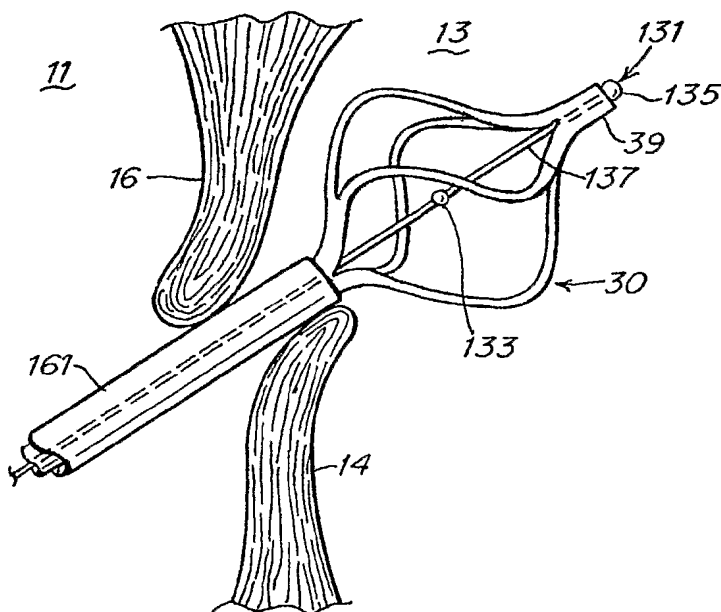

Fig. 9D

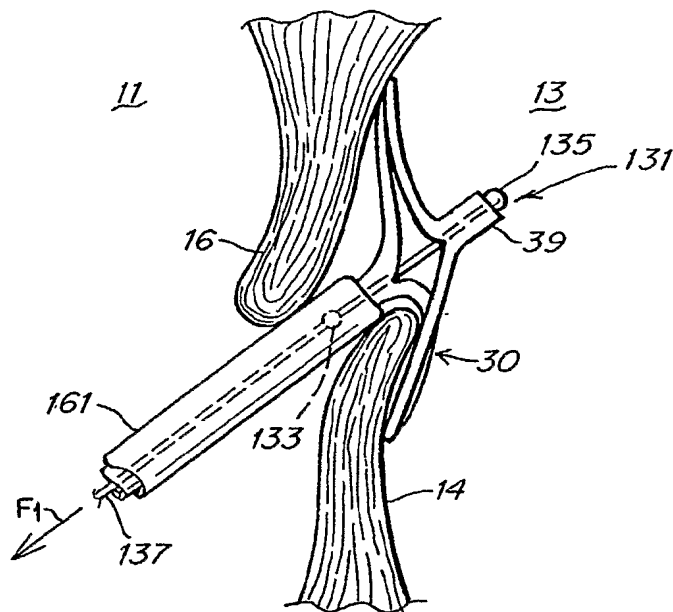

Fig. 9E

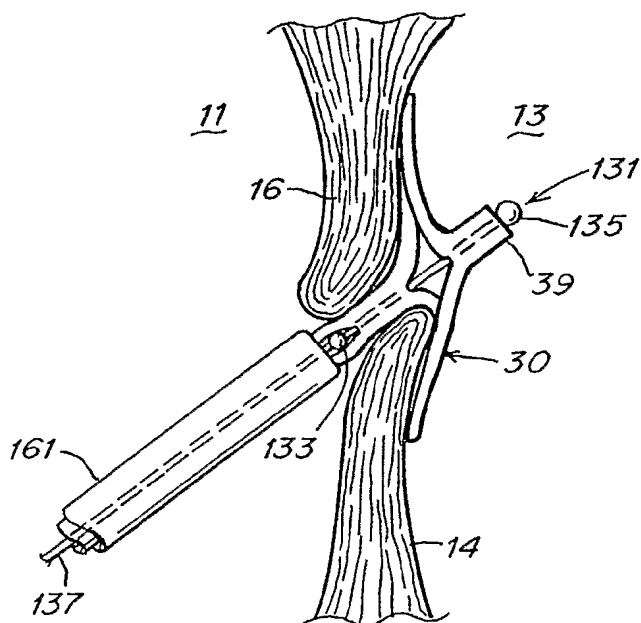

Fig. 9F

12/16

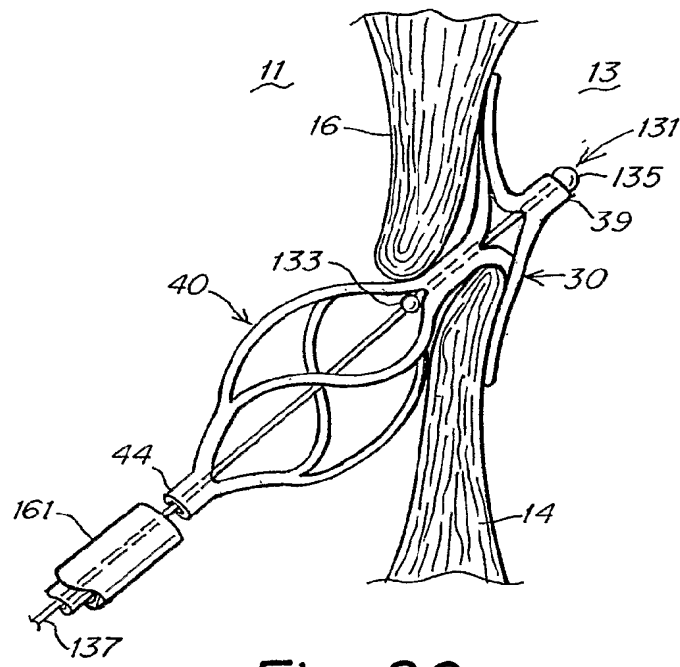

Fig. 9G

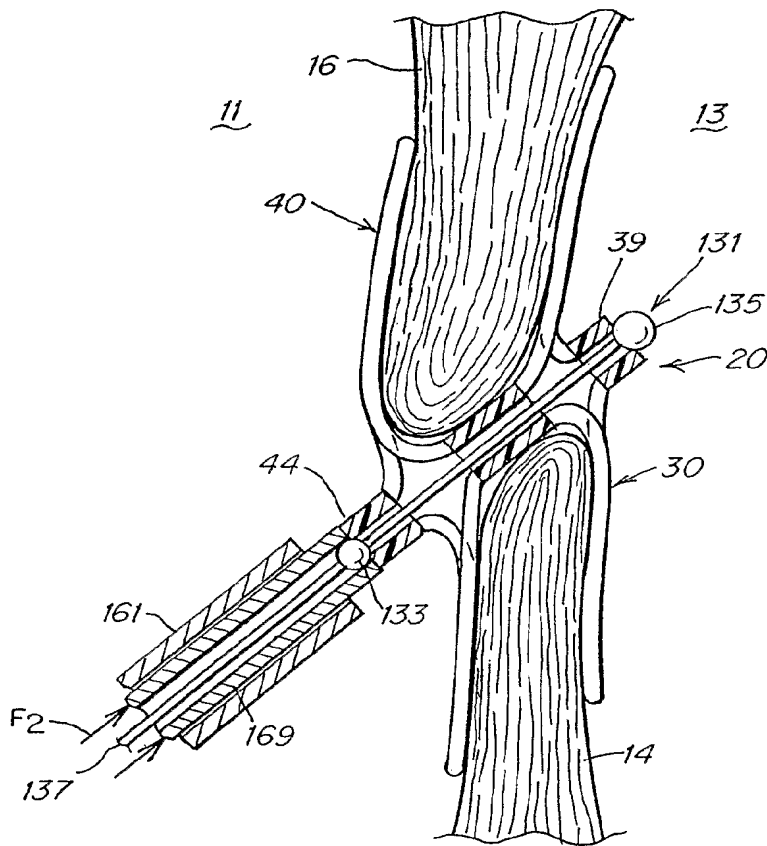

Fig. 9H

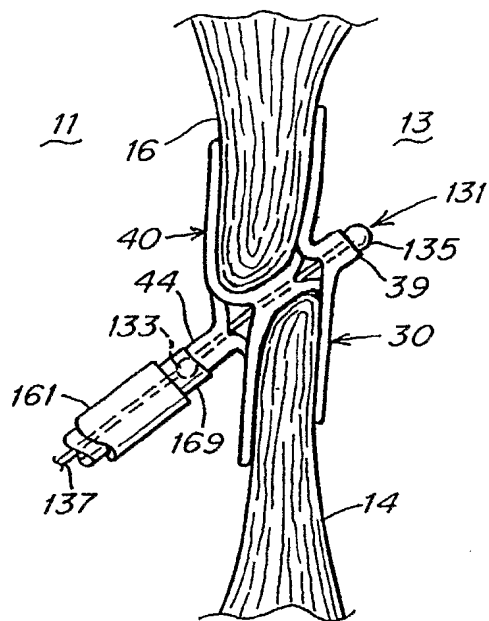

Fig. 10A

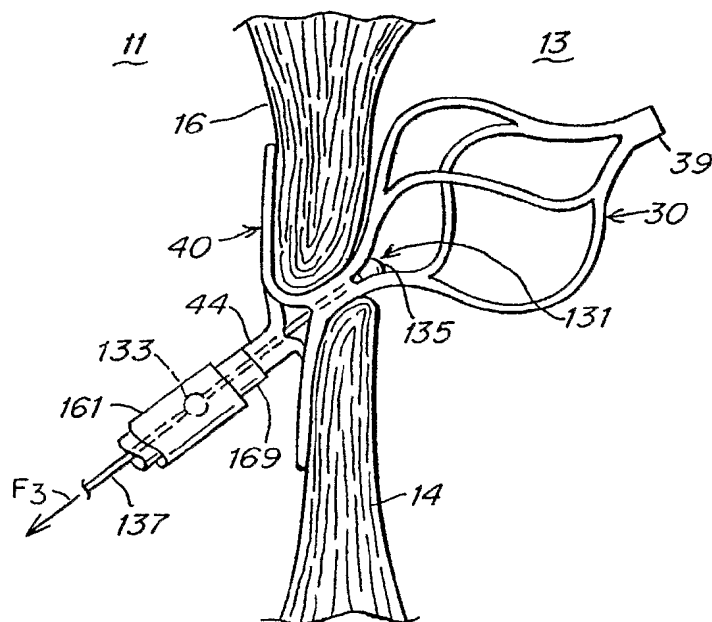

Fig. 10B

14/16

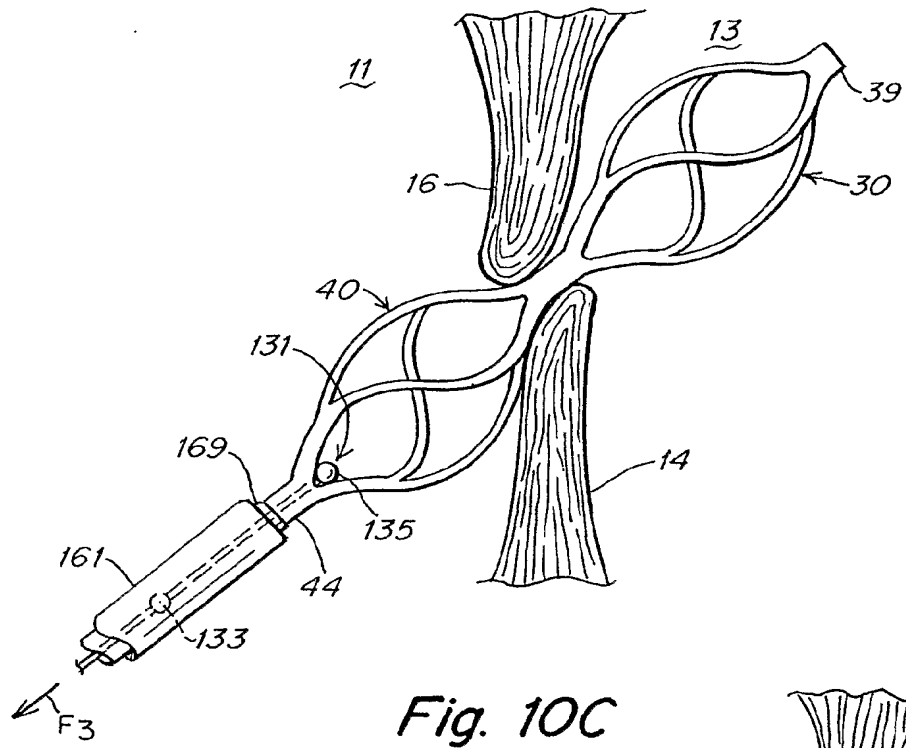

Fig. 10C

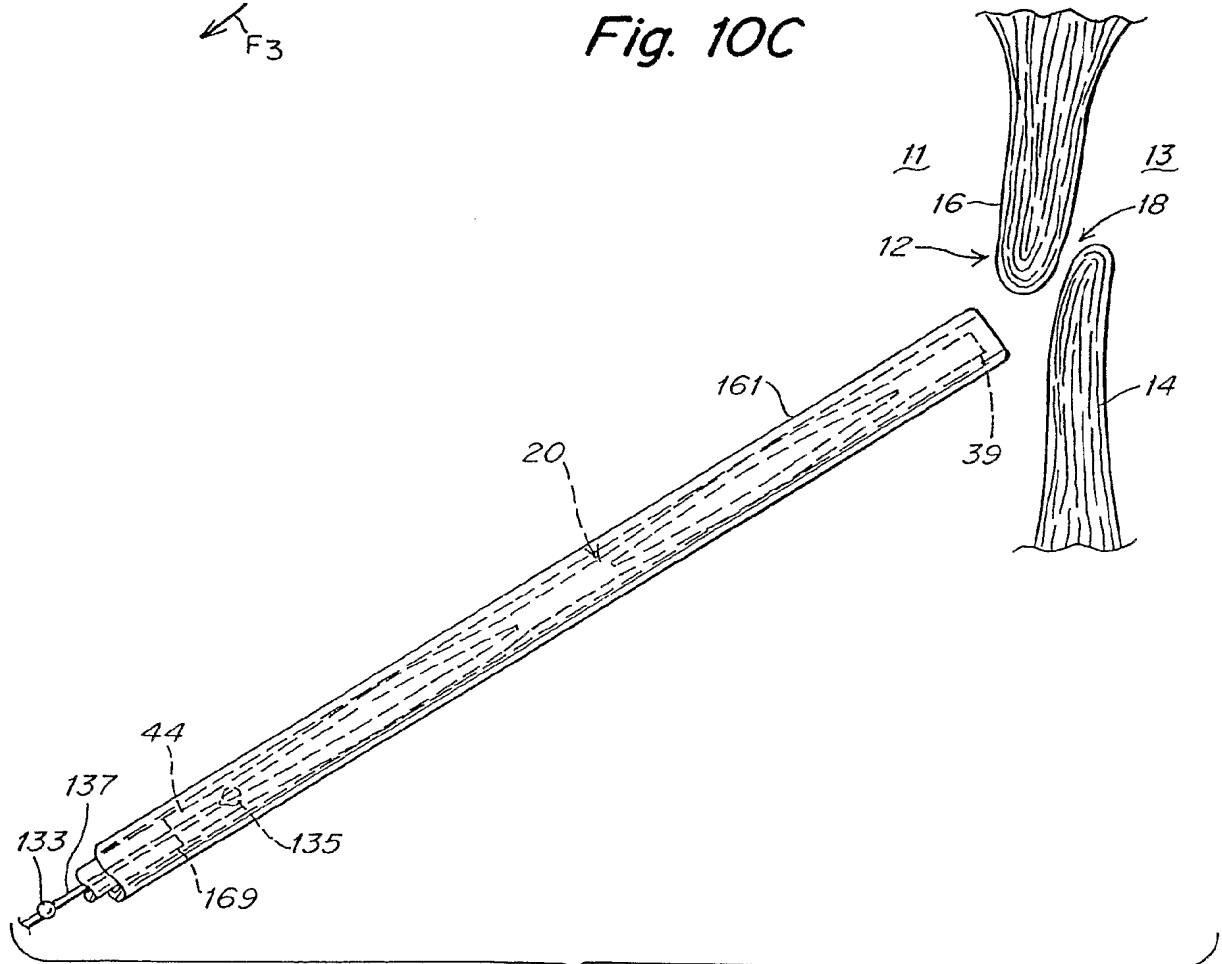

Fig. 10D

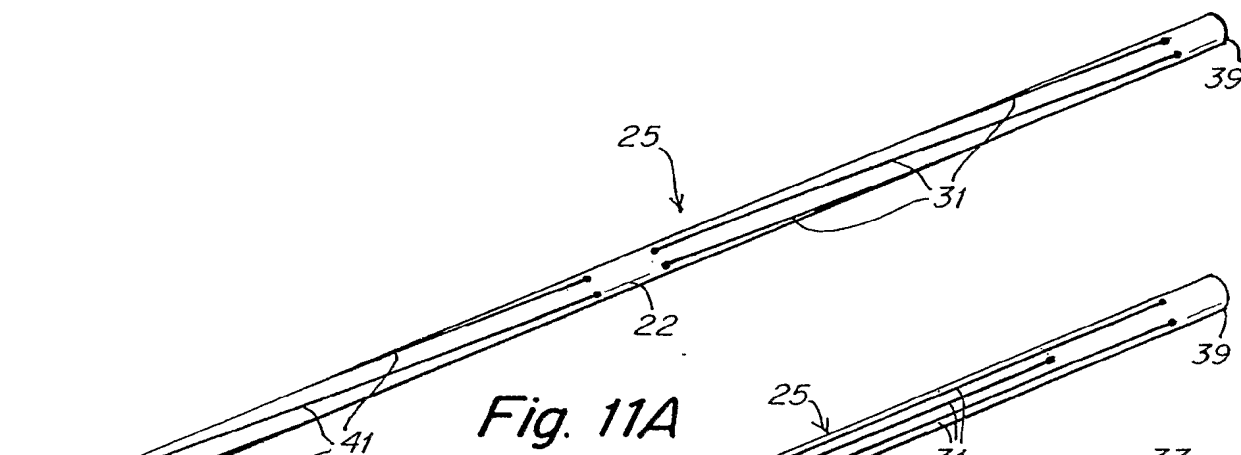

Fig. 11A

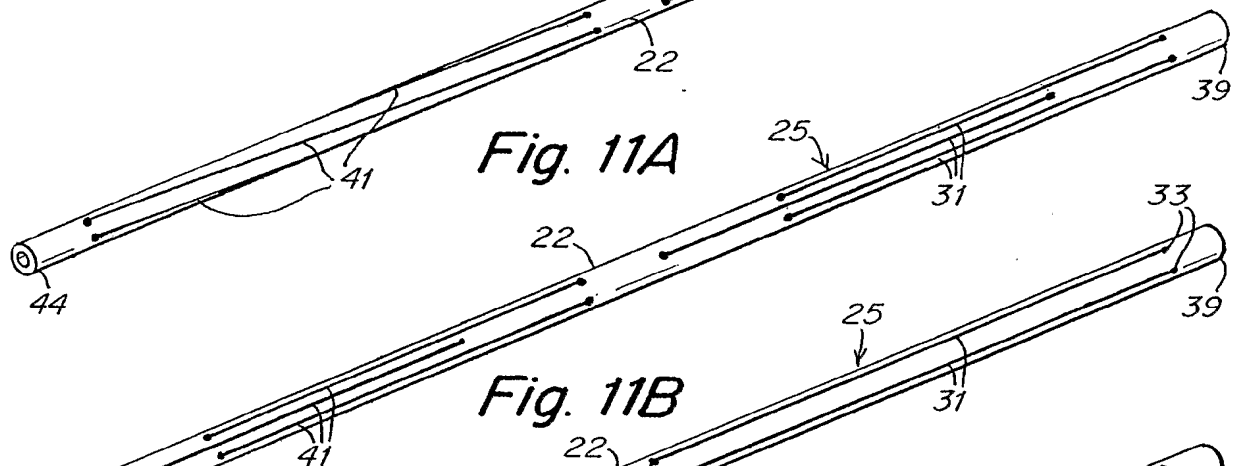

Fig. 11B

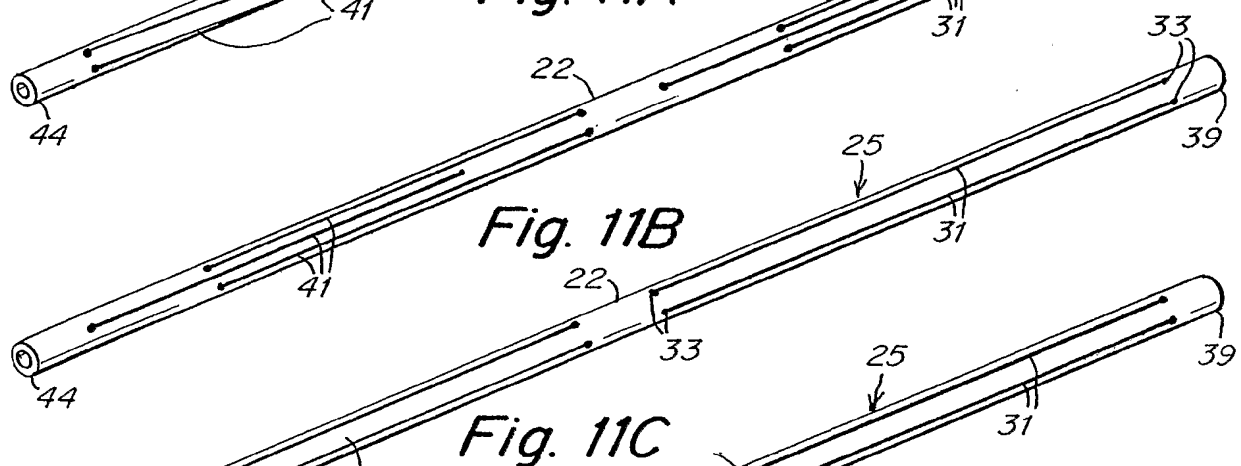

Fig. 11C

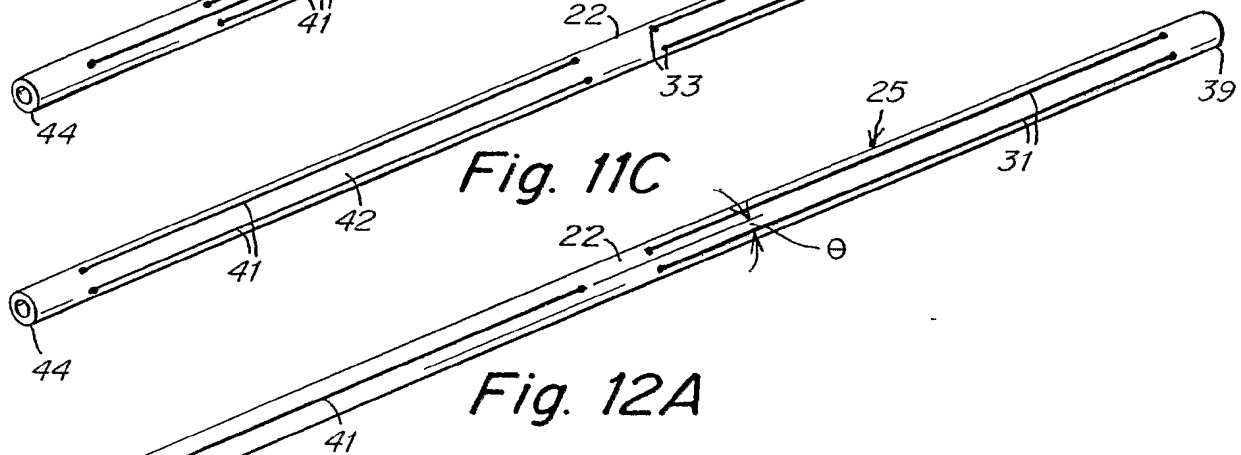

Fig. 12A

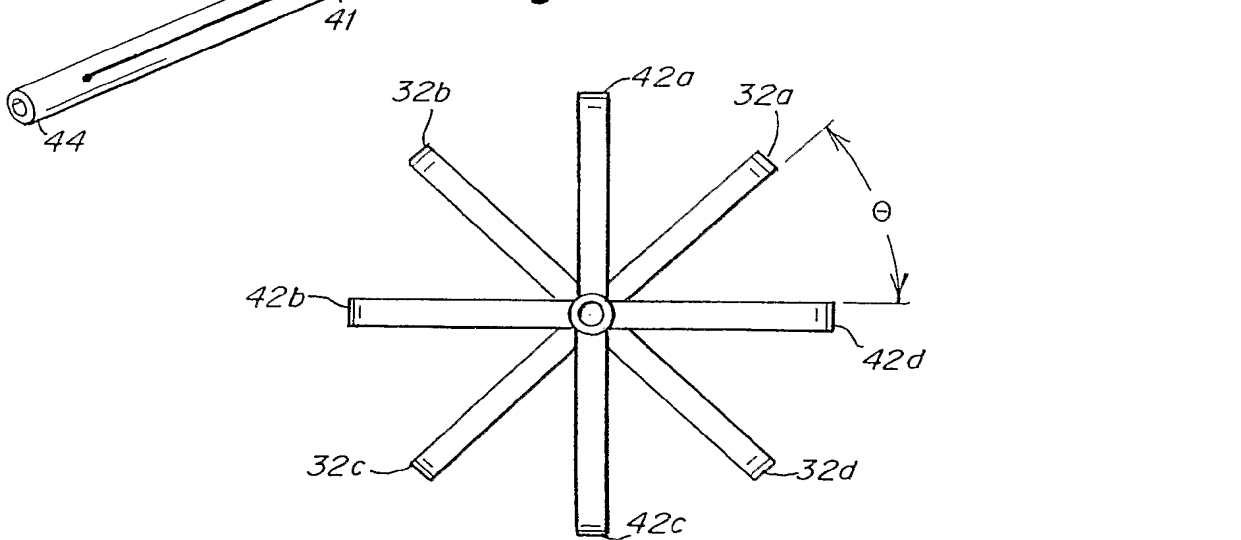

Fig. 12B

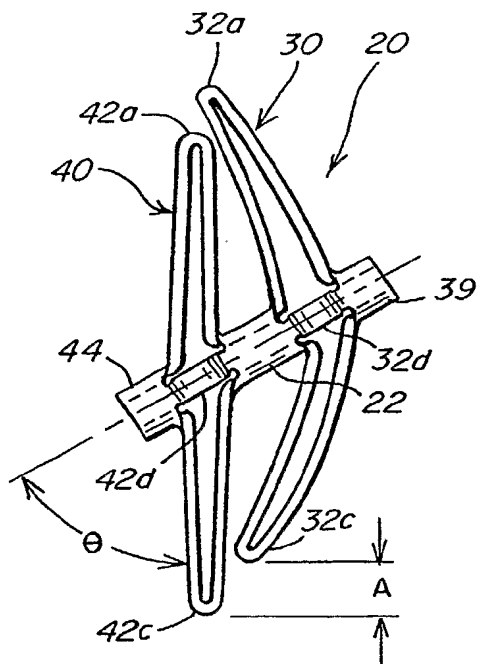

Fig. 13

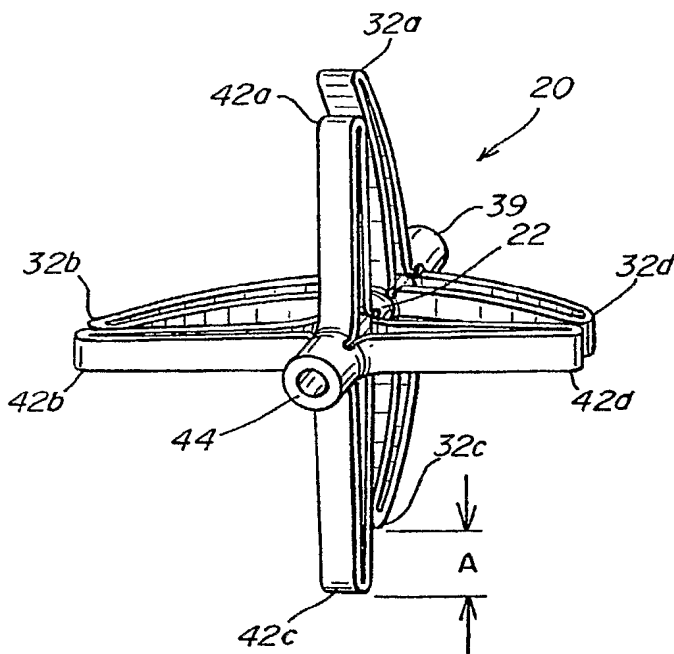

Fig. 14

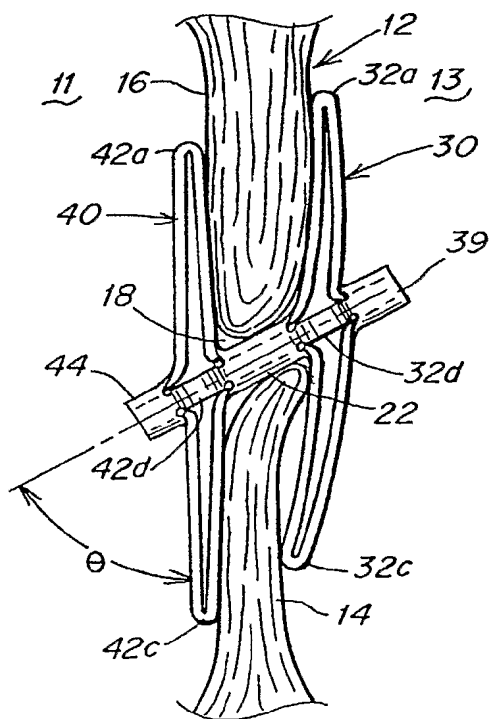

Fig. 15